

INSTRUCTIONS FOR MAINTENANCE AND INSTALLATION

(Model AT-1000 compressed air filter)

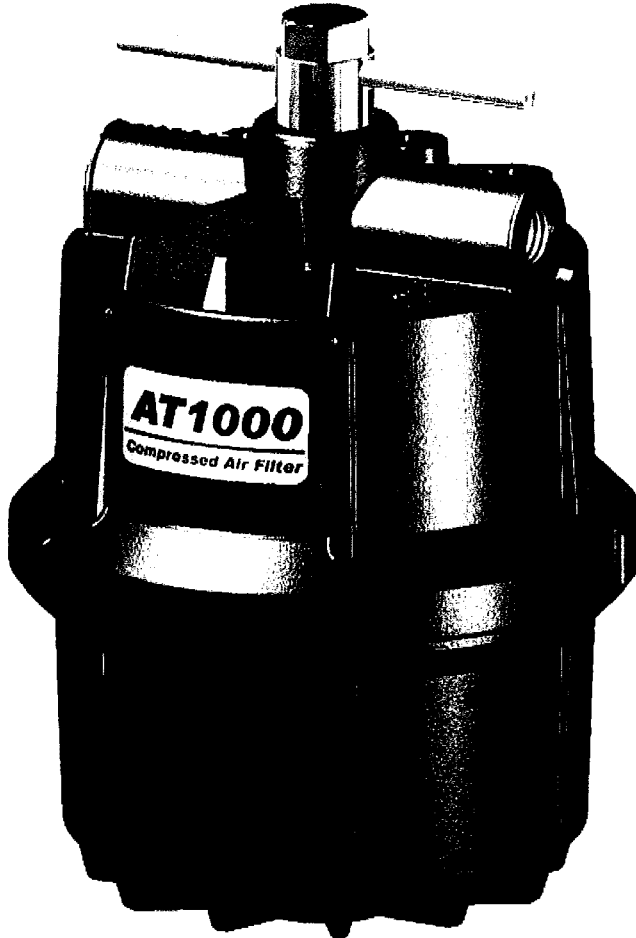

UNDER GENERAL INFORMATION

Our sub-micronic filter for compressed air has been designed to remove moisture, oil aerosols and particulates coming from air compressors, and provides clean, dry and oil-free air, essential for any industrial application.

The filter must be installed as close as possible downstream of the air pressure regulator, in addition to driers and other filters rather than replacement of the same. The filter AT-1000 will remove all oil aerosols, smokes, moistures and particulates passing through the conventional equipments.

The filter AT-1000 has an airflow rate of 1,250 lt/min - 2,700 SCFH (75 m³/h - 45 CFM) and it is supplied with 1/4 - 18 NPT female connectors, generally used by most of the systems.

UNDER BASIC INDUSTRIAL APPLICATIONS and RECOMMENDED SETTINGS

1. Plasma cutting systems - Install the filter on the top or rear side of the system and connect it to the air inlet.
2. Spray painting - Install the filter downstream of the pressure reducing valve.
3. Pneumatic tools of all types - Install downstream of the air pressure regulator but upstream of the lubricator.
4. Generic use of compressed air line - Install downstream of the air pressure regulator.

UNDER INSTALLATION

1. Connect fittings (purchased locally) to the inlet and outlet of the filter.
2. The filter can be installed on-line in the inlet of the system using fittings, or fixed to the system, or fitted to the wall with the brackets supplied.
3. Fix filter to brackets using screws and bolts supplied only (see drawing).
4. Install an air shut off valve upstream of the filter if required.
5. Make sure that the air pressure is lower than 8.5 Bars - 125 PSI.
6. Make sure to use air only, refraining from any other gas.

MAINTENANCE

As the filter cartridge is made of absorbent cellulose material, periodic changes are required.

The effective life of the filter cartridge depends on the amount of moisture generated by the air compressor, on the airflow rate speed and on the way of use.

Maximum water absorption capacity of the filter cartridge is about 250 gr. and it has to be replaced before it becomes completely saturated.

NOTE: Under extremely moist conditions install an automatic steam drier immediately upstream of the filter. It will remove most of the water, extending the filter cartridge life.

HOW TO REPLACE THE FILTER CARTRIDGE

1. Unscrew the "T" handle and remove the lower section of the filter.
2. Pull out the filter cartridge.
3. Clean the inside surface of the filter.
4. Insert the new filter cartridge in the lower section of the filter.
5. Close the filter by screwing the "T" handle by hand or by a 19mm or ¾" wrench.
Tighten with a tightening torque from 10 to 20Nm.

*To ensure the best filter performances, periodically lubricate the thread on stud with Vaseline grease.

THE CONTENT OF THE PACKAGING

1. Complete Air Filter, already assembled and ready to use.
2. Flat Bracket.
3. 90° Bracket.
4. N° 3 Self-tapping screws (to fix the flat bracket to the filter housing).
5. N° 6 Bolts M8 x 16.
6. N° 6 Flat washers Ø 8 mm.
7. N° 6 Nuts M8.

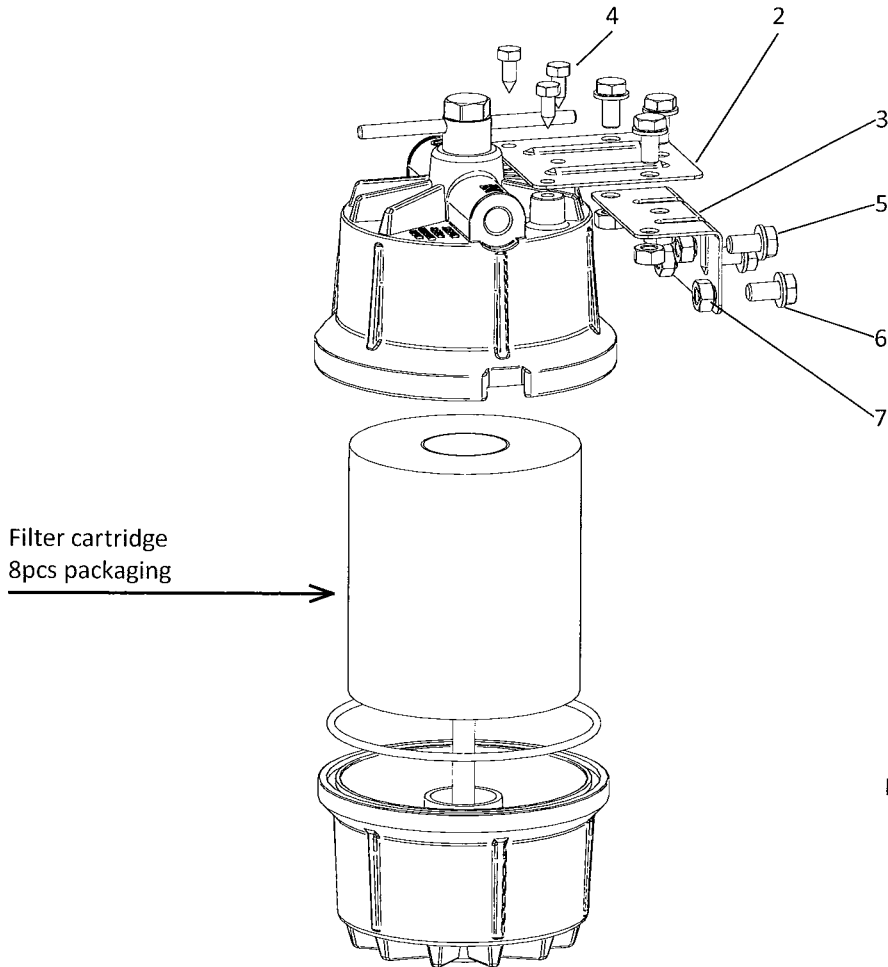

DATA SHEET

Filtering Degree:	.01 μ inch - 0.25 μ m
Maximum Pressure:	125 PSI - 8.5 bar
Maximum Flow @ 80%:	2700 SCFH - 1250 l/min.
Temperature Range:	15-140F / -10 +60C°
Size Pipe:	1/4 NPT
Dimension:	Ø5.2" x 7.9" - Ø132 x 200mm
