

INSTRUCTION MANUAL

PORTABLE MAGNETIC DRILLING MACHINE

Read this manual carefully before operating your Nitto Kohki Portable Magnetic Drilling Machine. Keep this manual with your machine. All users of the Nitto Kohki Portable Magnetic Drilling Machine must read this manual.

ATRA ACE Model CLA-2720 Professional Tool

For One-Touch Type Annular Cutter Only
(Side-Lock Type Annular Cutter cannot be used.)

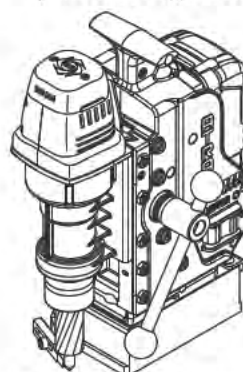

Specifications

Model		CLA-2720
Battery Pack		DC 18 V (Li-ion) MODEL :NBL18006
No-load Speed		430 min ⁻¹
Hole Capacity	JETBROACH One-touch type	Hole Diameter : : 12 to 17 mm dia. (Max.Plate thickness:12 mm) : 17,5 to 27 mm dia. (Max.Plate thickness:20 mm)
	Hi-BROACH One-touch type	Hole Diameter : : 12 to 15 mm dia. (Max.Plate thickness:12 mm) : 16 to 27 mm dia. (Max.Plate thickness:20 mm)
Magnet Dimension		65 mm x 126 mm
Magnet Holding Power		5500 N
Weight		7 kg(Handle Ass'y and Battery Pack are included.)
CHARGER		
Model		NC14435
Input voltage		220 - 240 V AC
Charging time		90 min
Weight		0.6 kg(Cord is not included.)

The specifications and configurations contained in this document are subject to change without prior notice due to improvements we are making day in, day out.

Manufactured by :



NITTO KOHKI Co., Ltd.
2-9-4, Nakaikegami, Ota-ku,
Tokyo, 146-8555, Japan
Tel : (81)-3-3755-1111
Fax : (81)-3-3753-8791
E-mail : overseas@nitto-kohki.co.jp
URL : www.nitto-kohki.co.jp

Keep the manual handy – so you can use it whenever necessary.

Original Instructions

Thank you very much for your purchase of **Nitto Kohki product**. Before using your machine, please read this manual carefully so that you may use it properly to get the most out of it.

Please keep the manual handy - so you can use it whenever necessary.

- English :Please ask your dealer or distributor for instruction manual in local language(s).
- German :Bitte fragen Sie Ihren Händler nach eine Betriebsanleitung in Landessprache.
- French :S'il vous plait, veuillez demandez á votre fournisseur de manuel instruction en langue locale.
- Spanish :Por favor, contacte con su distribuidor para el manual de instrucciones en español.
- Portuguese :Por favor pessa ao seo agente ou distribuidor o manual de instrucces ih linguagen local.
- Italian :Per Manuale Istruzioni in lingua locale Vi preghiamo di rivolgervi al rivenditore o distributore.
- Dutch :Vraag uw handelaar om een nederladstalige gebruiksaanwijzing.
- Swedish :Be er lokala Åtreförsäljare eller distributör om manualer pá svenska.
- Danish :Venligst henvend Dem til den danske distributør for instructions manualer.
- Polish :Prosze pytac swojego dealera lub dystrybutora o instrukcje obslugi w jezyku localnym.
- 中文 :請向當地供應商或經銷商詢問中文使用說明書

CONTENTS

	page
GENERAL SAFETY RULES	2
POWER TOOL SAFETY	3
GENERAL SAFETY RULES FOR CORDLESS MACHINE	5
ABOUT YOUR NITTO PORTABLE MAGNETIC DRILLING MACHINE	6
1. USAGE	9
2. CHECK THE CONTENTS OF THE PACKAGE	9
3. NAME OF PARTS	9
4. ELECTRONIC CONTROL FUNCTIONS	10
5. CHARGING METHOD	11
6. PREPARATIONS	12
7. MACHINE OPERATION	16
8. TROUBLESHOOTING	19
9. MAINTENANCE AND INSPECTION	19
10. ORDERING SERVICE PARTS	21
11. RECYCLE	22
12. ATRA ACE CLA-2720 ASSEMBLY	23
13. ATRA ACE CLA-2720 PARTS LIST	24

PICTOGRAM



Warning: It might be dangerous to operate the power tool if the instructions supplied are not followed.



Do not allow the main body or the power source to get wet as it will cause electric shock and leakage.



Using this tool improperly could result in serious injury. Read the instruction manual before using.



Always wear suitable eye protection.



Always wear suitable hearing protection.



Always wear respiratory protective equipment (PPE).

The following Safety notations are used throughout the manual to highlight safety precautions for the user and for the machine.

DANGER:	Indicates an imminently hazardous situation which, if not avoided by following the instructions given, will result in death or serious injury.
WARNING:	Indicates a potentially hazardous situation which, if not avoided by following the instructions given, could result in death or serious injury.
CAUTION:	Indicates a potentially hazardous situation which, if not avoided by following the instructions given, could result in injury or material damage.

Caution: Important precautions for machine or tool setup, operation and maintenance.

GENERAL SAFETY RULES

WARNING

TO OPERATORS

Always Wear Proper Clothing

Do not wear loose clothing. Loose clothing can become caught in the drilling machine. This could cause severe injuries. Be careful that loose clothing does not come into contact with the machine.

Wear non-skid footwear. If you lose your footing, you could contact moving portions of the machine. This could cause severe injuries. Always wear non-skid footwear and remain balanced when using the drilling machine.

Be careful of long hair. Wear a hat or a hair net to contain long hair. Long hair can become caught in the drilling machine. This will cause severe injuries. Be careful that long hair does not come into contact with the drilling machine.

Always Wear Suitable Eye Protection

Always wear suitable eye protection. The operation of your drilling machine will cause flying chips and particles. These will cause severe eye injuries. You must always wear suitable eye protection.

Not all glasses are suitable eye protection. Wear only suitable eye protection that comply with ANSI standards. Not all of the lenses are shock resistant. Ordinary glasses will not provide sufficient eye protection.

Glasses only for visual correction are not appropriate to be used as safety glasses.

Always Wear Suitable Hearing Protection

Always wear suitable hearing protection. The operation of your drilling machine will cause big sound occurs. These will cause severe hearing loss injuries. You must always wear suitable hearing protection.

Always Wear respiratory protective equipment (PPE)

Always Wear respiratory protective equipment (PPE) when working in an environment where dust particles are generated in operation.

Maintain Good Posture

Always wear non-skid footwear and maintain good posture. Do not use the drilling machine when you are tired. Fatigue or loss of balance could cause you to lose control of the machine. This could cause severe injuries. Always stay balanced. Always keep good posture. Stop using the machine if you are tired.

Never Touch the Cutting Tip

Never touch the moving or cutting tip. Contact with the moving tip will cause severe injuries. Always keep all parts of your body away from the cutting tip.

Always keep your hand and clothing away from the cutting tip.

ABOUT THE WORK AREA

Keep Work Area Clean

Always keep your work area clean. Cluttered work areas cause accidents. Always keep clear of other objects.

Never use the magnetic drilling machine when it is wet. Always use the drilling machine in a dry area. Do not use the drilling machine in the rain. If you use the machine when it is wet you can get electric shock. If you use the machine in the rain you can get an electric shock.

Always use the drilling machine in a well-lighted area. Do not use the drilling machine in the dark.

Avoid all flammable materials. Use of the drilling machine may cause a spark that could ignite a fire or an explosion. Never use the machine near any flammable material.

Keep away from children. Always keep the drilling machine away from children. Do not operate drilling machine when children are present.

BEFORE OPERATION

Make sure that all parts are free from damage

Make sure that the drilling machine is in good operating condition. Operation of a damaged machine could result in severe injuries. If there is any damage to the machine, do not use the machine. If there is any damage to the machine, take it to an authorized Nitto dealer for repair.

Do not attempt service or repair of the drilling machine. All service or repair should be done by an authorized Nitto dealer.

When a failure is observed with the switch, request for repair to the sales agent where the product was purchased or your nearest authorized Nitto dealer.

When a damage is observed with the power cord of the battery charger, request for repair to the sales agent where the product was purchased or your nearest authorized Nitto dealer.

Do not use the machine that cannot be started or stopped by the start switch.

Secure Your Work

Always secure your work piece. Improperly mounted work can become loose. This can cause severe injuries. Always secure all work.

Always use a vice or a clamp. Do not attempt to hold any work piece with your hand. Attempting to hold a work piece with your hand may cause severe injuries.

Always use a vice or clamp to hold the work piece.

Always secure your drilling machine. Improperly

mounted drilling machine can come loose. This can cause severe injuries. Always secure the drilling machine.

Avoid Clutter

Always stay clear of other objects. Cluttered work areas cause accidents. Always keep a clean work area and stay away from other objects.

Always Remove Spanner Wrenches and Adjustment Tools

Always remove spanner wrenches and adjustment tools after adjustments have been made to the drilling machine. Always remove all adjustment tools before using the drilling machine.

Always Use a Cutter that is Appropriate for Your Work

Always use a Cutter that is appropriate for your work. Avoid heavy-duty work that is beyond the capacity of your drilling machine. If the work exceeds the capacity of your drilling machine, this can cause accidents and severe injuries. Always use the drilling machine in accordance with its performance specifications.

SAFE HANDLING

Never leave the magnetic drilling machine unattended while it is running. When the machine is unattended, disconnect the power source. Do not leave the work area until the machine comes to a complete stop. Operating the machine while it is unattended can cause accidents that may result in severe injuries.

How to store the machine and battery pack.

Store the machine and battery pack at a dry area under 50°C when not in use. Also, keep the machine and battery pack out of the reach of children.

Pay attention when carrying the machine.

Keep your hands away from the start switch when carrying the machine.

Do not hold parts other than the handle to carry the machine.

MAINTENANCE

Do not take apart or modify your magnetic drilling machine.

Do not attempt to disassemble or modify your magnetic drilling machine.

Do not modify your magnetic drilling machine. Modifications can cause accident and severe injuries.

All service and repairs must be performed by an authorized Nitto dealer. Any attempt to service or repair the machine yourself may result in an accident and severe injuries.

Check all Parts for Damage.

Always inspect the magnetic drilling machine before use.

Always check that the pilot pin and cutter are in good condition. Use of the machine with worn pilot pins or worn cutter can cause accidents and severe injuries.

Inspect all cutter before you put them on the magnetic drilling machine.

Do not operate the magnetic drilling machine with a damaged or worn cutter. Do not operate the machine with a damaged or worn pilot pin. Do not operate the machine with any damaged accessory. Operating the machine with any damaged part or accessory can cause accidents and severe injuries. If there is any damage to the magnetic drilling machine do not operate the machine. Take it to an authorized Nitto Dealer for repair.

Always have the magnetic drilling machine repaired at an authorized Nitto dealer. Always take the magnetic drilling machine to an authorized Nitto dealer for service, repair and replacement parts. If you cannot locate an authorized Nitto dealer near you, please contact your sales representative.

Always use Nitto genuine parts. The use of improper or non-Nitto parts can cause accidents and severe injuries. Never use unauthorized parts. To obtain genuine Nitto parts, contact your sales agent.

Do not remove any nameplate from your magnetic drilling machine. Do not remove any labels from your magnetic drilling machine. If any label or nameplate is damaged contact your sales agent for a replacement.

When a damage is observed with the power cord of the battery charger, request for replacement at your nearest authorized Nitto dealer to avoid accidents.

GENERAL POWER TOOL SAFETY WARNINGS

⚠ WARNING

Read all safety warnings and all instructions. Failure to follow the warnings and instructions may result in fire and serious injury.

Save all warnings and instructions for future reference.

The term "power tool" in the warnings refers to your mains-operated (corded) power tool or battery-operated (cordless) power tool.

<Work area safety>

Keep work area clean and well lit. Cluttered or dark areas invite accidents.

Do not operate power tools in explosive

atmospheres, such as in the presence of flammable liquids, gases or dust. Power tools create sparks which may ignite the dust or fumes. **Keep children and bystanders away while operating a power tool.** Distractions can cause you to lose control.

<Electric safety>

Avoid body contact with earthed or grounded surfaces, such as pipes, radiators, ranges and refrigerators. There is an increased risk of electric shock if your body is earthed or grounded.

Do not expose power tools to rain or wet conditions. Water entering a power tool will increase the risk of electric shock.

<Personal safety>

Stay alert, watch what you are doing and use common sense when operating a power tool. Do not use a power tool while you are tired or under the influence of drugs, alcohol or medication. A moment of inattention while operating power tools may result in serious personal injury.

Use personal protective equipment. Always wear eye protection. Protective equipment such as dust mask, non-skid safety shoes, hard hat, or hearing protection used for appropriate conditions will reduce personal injuries.

Prevent unintentional starting. Ensure the switch is in the off-position before connecting to battery pack, picking up or carrying the tool. Carrying power tools with your finger on the switch or energizing power tools that have the switch on invites accidents.

Remove any adjusting wrench before turning the power tool on. A wrench left attached to a rotating part of the power tool may result in personal injury.

Do not overreach. Keep proper footing and balance at all times. This enables better control of the power tool in unexpected situations.

Dress properly. Do not wear loose clothing or jewellery. Keep your hair, clothing and gloves away from moving parts. Loose clothes, jewellery or long hair can be caught in moving parts.

<Power tool use and care>

Do not force the power tool. Use the correct power tool for your application. The correct power tool will do the job better and safer at the rate for which it was designed.

Do not use the power tool if the switch does not turn it on and off. Any power tool that cannot be controlled with the switch is dangerous and must be repaired.

Disconnect the battery pack from the power tool before making any adjustments, changing accessories, or storing power tools. Such preventive safety measures reduce the risk of starting the power tool accidentally.

Store idle power tools out of the reach of children and do not allow persons unfamiliar with the power tool or these instructions to operate the power tool. Power tools are dangerous in the hands of untrained users.

Maintain power tools. Check for misalignment or binding of moving parts, breakage of parts and any other condition that may affect the power tool's operation. If damaged, have the power tool repaired before use. Many accidents are caused by poorly maintained power tools.

Keep cutting tools sharp and clean. Properly maintained cutting tools with sharp cutting edges are less likely to bind and are easier to control.

Use the power tool, accessories and tool bits etc. in accordance with these instructions, taking into account the working conditions and the work to be performed. Use of the power tool for operations different from those intended could result in a hazardous situation.

<Battery tool use and care>

Recharge only with the charger specified by the manufacturer. A charger that is suitable for one type of battery pack may create a risk of fire when used with another battery pack.

Use power tools only with specifically designated battery packs. Use of any other battery packs may create a risk of injury and fire.

When battery pack is not in use, keep it away from other metal objects, like paper clips, coins, keys, nails, screws or other small metal objects, that can make a connection from one terminal to another. Shorting the battery terminals together may cause burns or a fire.

Under abusive conditions, liquid may be ejected from the battery; avoid contact. If contact accidentally occurs, flush with water. If liquid contacts eyes, additionally seek medical help. Liquid ejected from the battery may cause irritation or burns.

<Service>

Have your power tool serviced by a qualified repair person using only identical replacement parts. This will ensure that the safety of the power tool is maintained.

Hold power tool by insulated gripping surface,

when performing an operation where the cutting accessory may contact hidden wiring. Cutting accessory contacting a "live" wire may make exposed metal parts of the power tool "live" and could give the operator an electric shock.

Drill safety warnings

- **Wear ear protectors when impact drilling.**
Exposure to noise can cause hearing loss.
- **Use auxiliary handle(s), if supplied with the tool.**
Loss of control can cause personal injury.

GENERAL SAFETY RULES FOR CORDLESS MACHINE

WARNING

Do not use the battery pack other than for the cordless machine of Nitto.

Use the battery charger and battery pack specified by Nitto described in the instruction manual and catalog. Use of a battery pack not specified by Nitto may cause machine failure, injury or damage.

Do not use deteriorated battery pack.

Use of deteriorated battery pack may cause liquid leak, heat generation or explosion of the battery.

Use proper method for charging.

Use a power source appropriate for the rated voltage of the battery charger. Do not use power source of direct current or engine generator. It may cause failure or fire.

Do not charge the battery pack when the temperature is less than 0°C or over 40°C. It may cause explosion or fire.

Charge the battery pack at a well-ventilated area.

Do not cover the battery pack or battery charger with a cloth, etc. It may cause explosion, smoke or fire.

When not in use, unplug the power supply plug of the battery charger from the electric outlet. Leaving the machine plugged may cause electric shock, smoke or fire.

Do not use or charge at an area where there is flammable liquid or gas.

It may cause smoke, ignition or explosion.

Do not use or charge in rain or at damp or wet areas.

It may cause electric shock or smoke.

Do not short circuit between terminals of the battery pack.

Short circuit by water, cutting chips and other conductive materials may cause smoke, ignition or explosion.

Be careful of electric shock.

Do not touch the power supply plug, terminals or their peripheral areas of the battery pack and battery charger with wet hands. It may cause electric shock.

Turn the switch of the machine off and disconnect the battery pack from the machine in cases described below.

When not in use or when repairing.

When replacing accessories such as a drill.

When work is finished and storing the machine.

When other dangerous situation is assumed.

Avoid abrupt starting.

Check that the switch is turned off before attaching the battery pack. Do not touch the arbor or drill when attaching the battery pack.

Use specified accessories and attachments.

Use specified accessories and attachments described in this instruction manual and Nitto catalog. Use of other accessories and attachments may cause an accident or injury.

Do not place the battery pack in fire.

It may cause ignition or explosion.

If the liquid of the battery pack leaks and gets into your eyes, do not rub your eyes but immediately wash your eyes with plenty of clean water such as tap water and consult with a medical doctor.

If the liquid of the battery pack leaks and comes into contact with your skin or clothing, immediately wash with plenty of clean water and consult with a medical doctor since it may cause skin infection or injury.

Pay attention that the battery pack is clean from chips and dust.

Prevent chips to fall on the battery pack when working.

Do not leave the battery pack where chips or dust accumulate when the battery pack is not in use.

Clean off chips and dust when storing the battery pack and store it separately from metal parts.

Do not stick a nail or apply strong impact to the battery pack.

Do not apply heat or high pressure to the battery pack by putting it in a microwave or in a pressurized container.

Immediately move the battery pack away from fire when any leaking or smell is identified.

Do not use the battery pack for other devices.

Stop charging the battery pack when charging is not completed even after the specified charging time is significantly exceeded.

Do not use the battery pack that has external damage or significant deformation.

Do not use at areas where strong static electricity is generated.

- **Use appropriate machine for the intended work.**
Do not use small machine and attachments for work to be handled by large machine. It may cause injury.
- **Handle the battery charger cord gently.**
Do not carry the battery charger with the cord or do not unplug from the electric outlet by pulling the cord. Avoid damaging the cord by fabricating, excessive bending, placing close to high temperature area, pulling, twisting, bundling, placing heavy weight on it, inserting between objects, hooking on a metal part, etc.
- **Avoid using the product and hand it over to the sales agent where the product was purchased when rust, abnormal smell, heat generation or other abnormalities are observed when using for the first time after the purchase.**
- **Use the genuine battery pack of Nitto.**
Safety and warrantee for the product is not guaranteed when a battery pack not specified by Nitto or a battery pack that was disassembled or modified (includes battery packs that were disassembled and internal parts such as cells were replaced) is used.
- **Immediately remove the battery pack from the device or battery charger and avoid using it when abnormal smell at use, charging or storage is identified or when heat generation, discoloration, deformation or other conditions different from conventional condition is observed.**
- **Carefully maintain cordless machines.**
Maintain drills to have proper drilling performance at all times for safe and efficient work. Damaged drills may cause injury.
- **Pay sufficient attention during operation.**
Carefully perform the task by sufficiently paying attention to the handling method, work method and surrounding conditions when using cordless machines. Thoughtless actions may cause an accident or injury.
Use common sense. Senseless actions may cause an accident or injury.
- **Request for repair of cordless machines to specialized stores.**
Do not disassemble, repair or modify the machine, battery charger or battery pack.
Request for inspection and repair when heat generation or any abnormality is observed with the machine, battery charger or battery pack.
Request for repair to the sales agent where the product was purchased or your nearest authorized Nitto dealer. Repairing by yourself may cause an accident or injury.

⚠ WARNING

ABOUT YOUR NITTO PORTABLE MAGNETIC DRILLING MACHINE

- **Do not use the power supply for the engine powered welder.**
- **Do not operate on the ceiling.** The tool should be operated on a horizontal place or the wall (vertically). Do not operate the tool on the ceiling (upside down). (Fig. 1) Never use this unit at the work on ceiling (upside down).

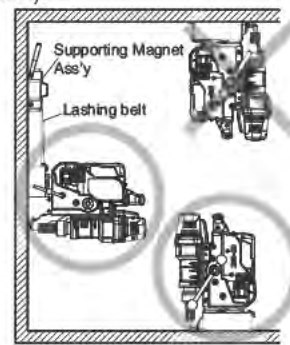

(Fig. 1)

- **Minimum workpiece thickness of 6mm.** If a workpiece is not thick enough, it will weaken the magnetism, preventing proper operation due to the slipping or lifting from the workpiece. When drilling a workpiece of insufficient thickness, it is recommended that a piece of iron, approximately 7mm thick and somewhat larger in size than that of the Magnet, be placed on the reverse side of the workpiece. (Fig. 2, Fig. 3)

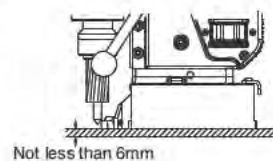

(Fig. 2)

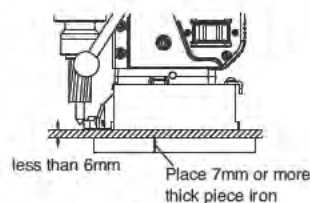

(Fig. 3)

- **Clean the adhesion surface of the Magnet and the surface of the workpiece.** Any gaps between the adhesion surface of the Magnet and the surface of the workpiece will weaken the adhesive power of

the Magnet and may cause the tool to swing around. Therefore the surfaces should always be kept clean and free from metal chips, bumps and depressions or rust. Also, do not place the Magnet over holes as this will also weaken the adhesion.

- **Provide fall prevention using lashing belt. (Fig. 4).** Attach the lashing belt attached to the belt attachment plate of the machine and fix the work piece to prevent drop or fall of the machine due to working in high places or wall surface or because of lifting of magnet by low voltage of the battery pack, etc. Use the Supporting Magnet Ass'y (optional) for fall prevention of the machine when the lashing belt cannot be wrapped around the work piece due to its large size. Properly fix the lashing belt using the buckle to prevent loosening of the belt lashing.

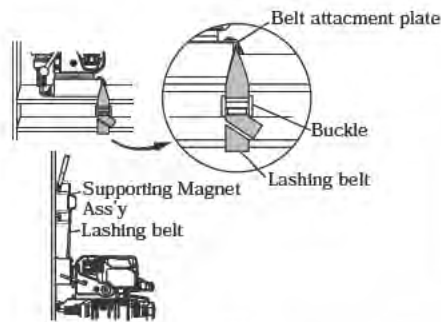

(Fig. 4)

- **Align the Magnet parallel to the length of the workpiece.** Since the surface of an H-section is normally curved as shown in Figure 6, the Magnet should be placed parallel to the length of the workpiece to ensure good adhesion and safe working. Insecure magnetic adhesion is the cause of cutter damage and unexpected accidents. (Fig. 5)

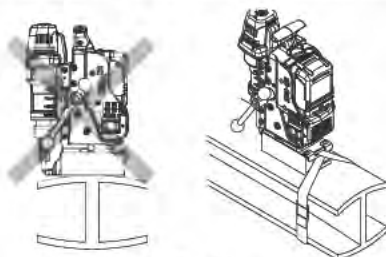

(Fig. 5)

- **Do not touch the rotating cutter or swarf with your hands, body, gloves, hair or clothes.**
- **Beware of slag being ejected when a hole is finished.** Wear protective gear since slag (metal chips) is ejected with great force when a hole is finished. Do not allow unprotected people

to approach the work site. When working in high places, make sure there is no one underneath and be very careful of falling slag. The slag is hot, do not touch it with bare hands.

- **When clearing away metal chips, set the Magnet Switch to Off.** Do not touch the chips with your hands, use a rod such as a screwdriver to remove them.
- **When replacing cutters, do not touch the cutting blades with bare hands.**
- **You must use a Pilot Pin which matches the cutter.** Pilot Pins differ according to cutter type, diameter and length (depth). An accident may be caused if the cutter and Pilot Pin combination is wrong. Refer to item 6-3 cutter and Pilot Pin Combinations.
- **Do not use Cutting Oil for other purposes.** Refer to item 6-7 Preparing the Cutting Oil.
- **Do not remove labels or name plates from the tool.** Contact the sales agent from whom you purchased the tool or an authorized dealer if a label or name plate is damaged or missing.
- **When you put the machine back to the carrying case, please make sure to let out the cutting oil from Oil Tank.**

⚠ CAUTION

- **Non-magnetic (aluminum, stainless steel, copper alloy, etc.) workpiece can not be used since the Magnet will have no adhesion to it.**
- **Do not apply excess force on feed during manual drilling.** HI-BROACH and JETBROACH have thin cutter blades with lower cutting resistance than twist drills. Therefore they should not be fed forcibly manual drilling. Be careful because if more than necessary force is used the cutters will be damaged and their useful life will be shortened.
- **Never touch the drill after attaching the battery pack to the machine.**
- **Make sure that nobody is underneath the work area when working in high places.**
- **Securely attach the battery pack.**

Do not discard the battery pack with normal garbage or place in fire.

Keep the battery pack out of the reach of children.

Use the battery pack properly following the indicated specifications.

WARNING

This machine is not water proof.

Use the machine following the description below.

Immediately wipe the electric drill or the machine when any liquid such as cutting fluid or water is applied.

Do not operate with wet hand.

Do not use in rain.

CAUTION

Do not force feed the cutter while drilling manually.

Jetbroach and Hi-Broach cutters use a reduced wall thickness to minimize cutting resistance, resulting in faster hole productivity and less shavings. Pressure required to feed a Jetbroach or Hi-Broach cutter is far less than that of a twist drill bit; if too much pressure is applied to the cutter, life and or breakage may result.

The color of LED changes according to the load of the electric drill. Use it with LED in green or yellow.

LED turns green or yellow when the load of the electric drill is in normal condition and turns or blinks in red when it is in overload condition. Decrease the feeding rate of the drill when LED is turned or blinking in red since the electric drill is in overload condition and obtain a load with LED in green or yellow when drilling.

The power of the electric drill drops when excessive load is applied to the electric drill and LED starts blinking rapidly in red. When load is applied continuously, the machine will automatically stop and LED will start blinking in white.

When further load is applied to the electric drill even when LED is turned or blinking in red, the power of the electric drill drops to protect the electric drill and battery pack. The electric drill returns to normal operation when the load is decreased before it stops automatically due to overload. If the electric drill stops automatically, turn the switch off and then turn the switch back on to continue the operation.

Store the machine by keeping the electric drill at lowered position when not in use.

The machine may fall when stored with the electric drill at a lifted position.

When energized, the magnet may exhibit a buzzing sound or a slight hum.

1 USAGE

This is a machine tool which attaches magnetically to mild steel and uses the power of Drill Motor to drill holes with JETBROACH One-touch type or HI-BROACH One-touch Type.

2 CHECK THE CONTENTS OF THE PACKAGE

Check the contents and make sure that the tool is not damaged due to an accident during the transportation, if any. The contents should correspond to the list as follows. Just in case there are some damaged or missing parts, contact the sales agent from whom you purchased the tool or an authorized dealer.

THE CONTENTS OF THE PACKAGE AND ACCESSORIES

CLA-2720

Package Contents	Q'ty	check
ATRA ACE	1set	
Hex. Socket Screw Key 3	1	
Hex. Socket Screw Key 4	1	
Spanner 8x10	1	
Battery Charger	1set	
Battery Pack	2set	
TUBE 4x7	1	

Package Contents	Q'ty	check
Cutting Oil 0.5 Can	1	
Handle Ass'y	1	
Lashing belt	1	
Jet Oiler (No.3013)	1	
Instruction Manual	1	
Guard	1	
Hex. Socket Set Screw 8x28	1	
Hex. Socket Head Cap Screw 5x12	1	
Blade	1	

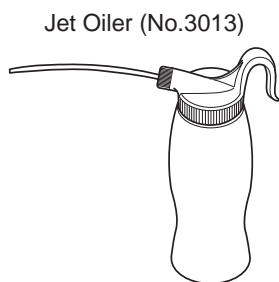

(Fig. 6)



(Fig. 7)

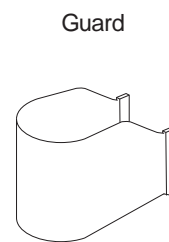

(Fig.8)

3 NAME OF PARTS

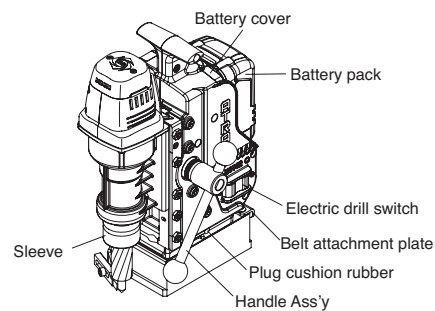
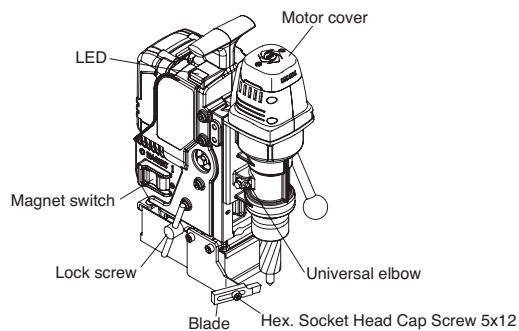

(Fig. 9)

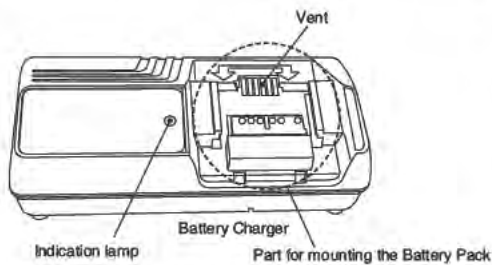

(Fig. 10)

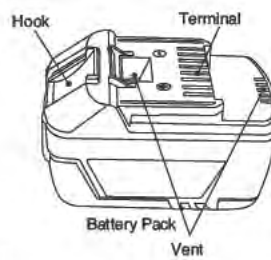

(Fig. 11)

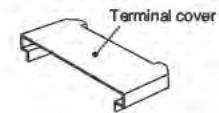

(Fig. 12)

4 ELECTRONIC CONTROL FUNCTIONS

4-1 Load Detection Function

Functions below automatically perform when overload is generated at drilling.

Load condition of the electric drill is indicated by turning on or blinking of LED.

LED indication	Load condition
Green ●	Normal
Yellow ●	Normal
Red ●	Overload
Red ☼	Overload
Red ☼ (Rapid)	During automatic stop function control Returns to normal control when load is released.
White ☼	Overload automatic stop Operation continues when the electric drill switch is turned off and turned back on.

● : Turned on
☼ : Blink

4-2 Battery Remaining Power Display Function

LED blinks three times in a color according to the remaining power of the battery right after the magnet switch is turned on.

LED indication	Battery remaining power condition
Green ☼	Approximately fully charged
Yellow ☼	Remaining power has decreased slightly
Red ☼	Remaining power has decreased significantly. Replace the battery pack to a charged battery pack.

☼ : Blink

4-3 Magnetic Force Control Function

Magnetic force is controlled when the electric drill is not operating with the magnet switch turned on to reduce unnecessary electricity consumption and maintain appropriate magnetic force.

⚠ CAUTION

The magnetic force drops completely when voltage of the battery pack decreases to a certain level and may cause the machine to fall.

Turn the magnet "OFF" when finished with the machine to preserve battery life.

4-4 Various Safety Functions and Error Detection Functions

LED indication is displayed as described in the table below according to the contents of safety functions and error detection functions.

Function name LED indication	Description of function and countermeasure
Restart prevention function Green ●	Magnet adhesion operates even when the magnet switch is turned on in a condition where the electric drill switch is turned on or even when the battery pack is attached in a condition where the magnet switch and electric drill switch are turned on. However, the electric drill will not operate for safety and LED blinks in green. Turn the electric drill switch off and then turn the switch back on to continue the operation.
Warning function Red (Rapid) ☼	Warning function is activated in operations described below for safety. • When the magnet switch is turned on in a condition where the battery pack is attached and the battery cover is open (condition where it is pushed toward the main body). Make sure to draw the battery cover toward the battery pack before starting the operation. (Fig. 23) • When the battery cover is pushed toward the main body to detach the battery pack before turning the magnet switch off Make sure to detach the battery pack after turning the magnet switch off.

Function name LED indication	Description of function and countermeasure
Magnet wire disconnection detection function Yellow	The electric drill will not operate and LED blinks in yellow when abnormality is generated with the magnet. Request for repair to the sales agent where the product was purchased or to your nearest authorized Nitto dealer.
Lateral slip detection function Blue	The electric drill stops and LED blinks in blue when lateral slip is generated with the magnet or abnormality such as wire disconnection is detected with the lateral slip detection device during drilling. Turn the magnet switch off and then turn the switch back on to continue the operation. When LED is blinking in blue and the electric drill does not start right after the magnet switch is turned on, the lateral slip detection function is defective. Request for repair to the sales agent where the product was purchased or to your nearest authorized Nitto dealer.
Electric drill overload stop function White	The electric drill stops and LED blinks in white when overload is applied and stops the electric drill during drilling. Turn the electric drill switch off and then turn the switch back on to continue the operation.
Remaining battery power drop detection function Red	LED blinks in red when the remaining battery power drops in a condition where the magnet switch is turned on. Turn the magnet switch off and immediately charge the battery pack.
Electric drill circuit abnormality detection function Red ↔ Green	LED blinks in red and green alternately when the control circuit of the electric drill is defective. Request for repair to the sales agent where the product was purchased or your nearest authorized Nitto dealer.
Wasteful operation warning function Green (Rapid)	When no operation is performed for a certain amount of time after the magnet switch is turned on or when no load is applied for a certain amount of time after the electric drill is started, it will be taken as wasteful operation and stops the electric drill with LED blinking rapidly in green to draw attention. The indication is stopped by starting the electric drill or applying load.

● : Turned on

: Blink

5 CHARGING METHOD

WARNING

- Charge at an area where the temperature is between 0°C to 40°C.
- Check the specification of the power source before plugging the supply plug to the electric outlet.
Do not connect to power sources with other voltage.
- Do not charge a battery pack other than the specified battery pack.
- Before attaching the battery pack to the battery charger, check that the battery pack and battery charger is clean from conductive cutting chips and water.

(1) Plug the power supply plug in the electric outlet.

The charging condition indication lamp changes to green → red → yellow.

(2) Attach the battery pack to the battery charger.

The charging condition indication lamp changes according to the status as described below after attachment.

Charging condition indication lamp	Battery charger condition
Green	Waiting for charging
Red ●	Charging
Green + Buzzer ●	Charging completed. Buzzer is activated for few seconds to notify the completion of charging.
Red	Standby for charging due to high temperature of the battery pack. Charging will start automatically when the battery pack is cooled by internal fan and the temperature is lowered.
Orange	Cannot start charging due to defect in the battery pack. Replace with a new battery pack.

● : Turned on

: Blink

(3) Detach the battery pack after charging and unplug the power supply plug from the electric outlet.

6 PREPARATIONS

⚠ WARNING

Turn the magnet switch off and detach the battery pack from the machine when preparing.

6-1 Attaching handle Ass'y

<Attachment and detachment of handle Ass'y >

1. How to attach the handle Ass'y

- Insert the sleeve of the handle Ass'y in the pinion shaft while the sleeve is pulled toward the handle. (Fig. 13)
- After it is attached, check that the handle Ass'y will not be detached before use.
- * The handle Ass'y can be attached on either right or left of the machine. (Fig. 14)
- * When the handle Ass'y interferes with the lock screw, attach the lock screw on the opposite side of the handle Ass'y. Refer to 7-2-(3) Aligning with Punch Mark for attaching the lock screw.

2. How to detach the handle Ass'y

- The handle Ass'y can be detached by pulling the sleeve of the handle Ass'y toward the handle.

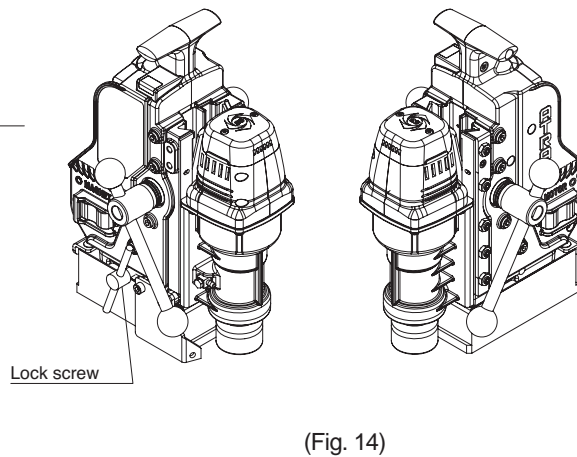
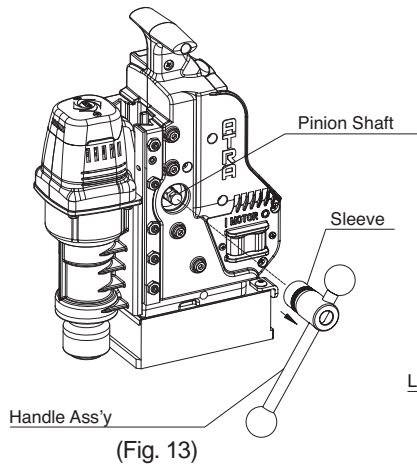

6-2 Cutter Usage

⚠ CAUTION

Cutters other than one-touch type can not be used. For better working and greater safety, do not use worn or broken cutters. When you need one-ouch type cutters or accessories, refer to 10. Ordering Service Parts.

6-3 Cutter and Pilot Pin Combinations

⚠ WARNING

You must use a Pilot Pin which matches the cutter. Pilot Pins differ according to cutter type, diameter, and length (depth). An accident may be caused if the cutter and Pilot Pin combination is wrong.

Match the appropriate Pilot Pin to the cutter which is to be used. (Fig. 15)

Pilot Pin	HI-BROACH Cutters
06025 PN : TK01167 6.35 dia. ↓ 5 dia. 81 mm	HBO 12 to 17mm dia. Depth 25 mm
08025 PN : TJ12696 76 mm	HBO 17.5 to 27mm dia. Depth 25 mm
Pilot Pin	JETBROACH Cutters
06025 PN : TK01167 6.35 dia. ↓ 5 dia. 81 mm	JBO 12 to 17mm dia. Depth 25 mm
08035 PN : TJ15859 81 mm	JBO 17.5 to 27mm dia. Depth 35 mm

(Fig. 15)

Pilot Pins differ according to the type, diameter and length (depth) of the cutter. If the cutter and Pilot Pin combination is wrong, the cutter will be damaged due to failure to eject the slag (metal chip) or poor Cutting Oil supply.

- Unspecified usage not only significantly reduces the life of the cutter but also damage the cutter and lead to unexpected accidents.

6-4 Mounting and Dismounting the Cutter

⚠ WARNING

- Do not touch cutting blades with bare hands.

⚠ CAUTION

- Pay attention to prevent cutting chips entering in the drill insertion area. When cutting chips have entered the drill insertion area, make sure to remove the cutting chips before attaching the drill.

(1) Raise the Drill Motor by turning the Handle Ass'y. (Fig. 16)

(2) Take the Pilot Pin which suits the size of cutter to be used and insert the Pilot Pin in the cutter. (Fig. 17)

(3) Align the depression in the cutter with the white line on the Sleeve and insert the cutter. (Fig. 18) When the cutter is pushed right in, the Sleeve can be turned to the right and will lock into place with a click.

※ If the cutter will not go in, turn the Sleeve to the left and try again.

(4) To remove the cutter, turn the Sleeve to the left and pull out the cutter. (Fig. 19)

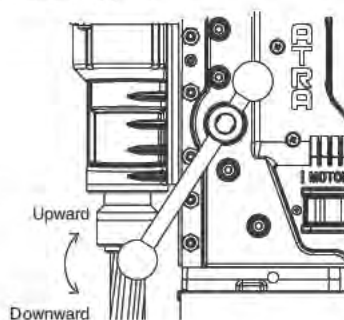

(Fig. 16)

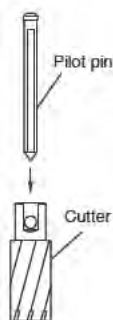

(Fig. 17)

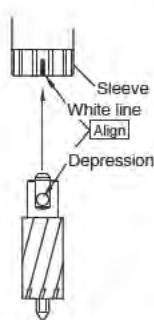

(Fig. 18)

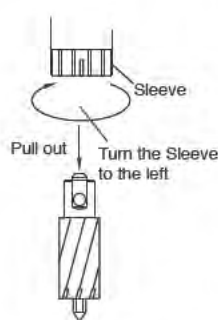

(Fig. 19)

6-5 Preparation of Chip Breakers

⚠ WARNING

- Set the Chip Breaker so that the tips of the blade may not interfere with the cutter both at the top and bottom in setting up the Chip Breaker.
- Make sure that no gap is created between the magnet adhesion surface and work piece due to the force of blade applied to the work piece.

The magnetic force significantly drops and is dangerous when there is a gap between the work piece and the magnet adhesion area.

⚠ CAUTION

- Cutting performance deteriorates and the drill may get damaged or the service life decreases when the chip breaker is not properly used.

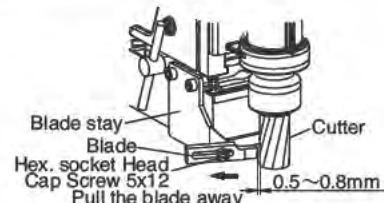

(Fig. 20)

Chip Breaker is to shred down cutting chips in randomly short length that are produced during the drilling operation for easy discharge of the succeeding cutting chips.

Setting the blade (see the fig.20)

(1) Mounting the cutter

Loosen the Hex. Socket Head Cap Screw and retract the Blade in the arrow direction until it can not retract any further, and then mount the cutter.

(2) Setting the blade

Set the Blade with the gap between the cutter and tip of the blade being 0.5mm to 0.8mm, securely mount it on the Blade Base with the hex. socket head cap screw.

6-7 Preparing the Cutting Oil

Safety Notes on Cutting Oil should be observed.

⚠ WARNING

(1) Application and Usage Limitations

- Use only as cutting fluid. Not for use in ordinary households.

(2) Precautions on Handling Cutting Oil

- This liquid contains amines. It should not be mixed with rust preventives containing nitrite.

- May cause inflammation if it enters the eyes. Protective eye-wear should be used when handling to prevent entry into the eyes.
- Skin contact may cause inflammation. Protective gloves should be worn when handling to prevent contact with the skin.
- May cause discomfort if mist or vapor is inhaled. Breathing apparatus should be used when handling so that mist or vapor should not be inhaled.
- Dilution should be carried out in accordance with the Instruction Manuals.
- Keep it out of reach of children.
- Do not drink it.

(3) Emergency Treatment

- If it has entered eyes, immediately open the eyelids as wide as possible and wash thoroughly with water for at least 15 minutes. If there is inflammation, consult a physician and follow the instructions.
- If it has contacted the skin, wash immediately with soap and water. Soiled clothing should be removed and laundered thoroughly before re-use. If there is inflammation, consult a physician and follow the instructions.
- If mist or vapor has been inhaled, immediately transfer the patient to fresh air, cover his/her body with a blanket and keep warm and quiet. Consult a physician and follow the instructions.
- If it has been ingested, immediately give copious water and induce vomiting. Consult a physician and follow the instructions. If the patient is unconscious, do not administer water or induce vomiting.

(4) In Case of Fire

- For a fire in the vicinity, wear protective equipment and extinguish the fire approaching from the windward side with foam, powder or CO₂ fire extinguishers.

(5) Method of Storage

- Seal after use to prevent admixture with dirt and/or water.
- Store in a cool dark place away from direct sunlight and rain.

(6) Method of Disposal

- Disposal of undiluted and diluted fluid should be handled as waste fluid in accordance with the law by a waste disposal specialist.
- Wash water should be treated by pH adjustment, flocculation and settling, activated sludge treatment, activated carbon absorption, etc., and discharged in accordance with municipal standards.
- Since empty containers contain dregs, they should be

handled with care.

(7) Other

- If transferred to other containers for use, the names of chemicals used in the workplace and the labeled contents should be displayed and kept together with the Instruction Manuals ready for immediate perusal.
- Anyone wishing to have further details may request product safety data sheets from manufacturer.
- The inscribed details are based on currently available information and data and updated by new knowledge.
- Items to be noted are aimed at normal handling. Where special handling is involved, safety measures appropriate to the application and method of handling should be implemented.
- The inscribed details are submitted for your information and do not imply assurances or acceptance of responsibility.

⚠ CAUTION

- (1) Use Nitto genuine blue Cutting Oil. Cutting performance and life may be reduced when other Cutting Oils are used.
- (2) Dilute the Cutting Oil in the proportion of eight to ten times with tap water. Do not use well water for dilution.
- (3) Put the cutting oil in the supplied jet oiler and connect to the universal elbow of the machine using a tube of 4 × 7 × 1000. (Fig. 21)

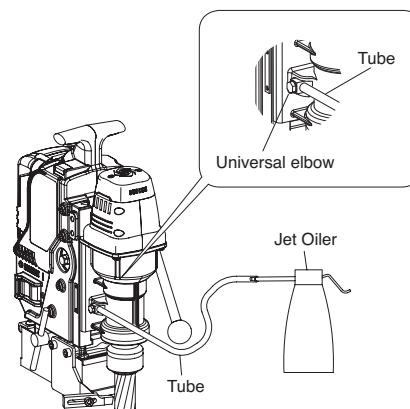

(Fig. 21)

6-8 Attachment of Battery Pack (Fig. 22)

⚠ WARNING

- Check that there is no cutting chips or water on the battery pack and machine before attaching the battery pack.
- Securely attach the battery pack.

(1) Check that the magnet switch and electric drill switch are turned off.

(2) Push the battery cover toward the main body.

(3) Attach along the groove of the machine while pressing the hook of the battery pack. Make sure to check that it is locked with a clicking sound and check that it does not get detached.

(4) Draw the battery cover out toward the battery pack.

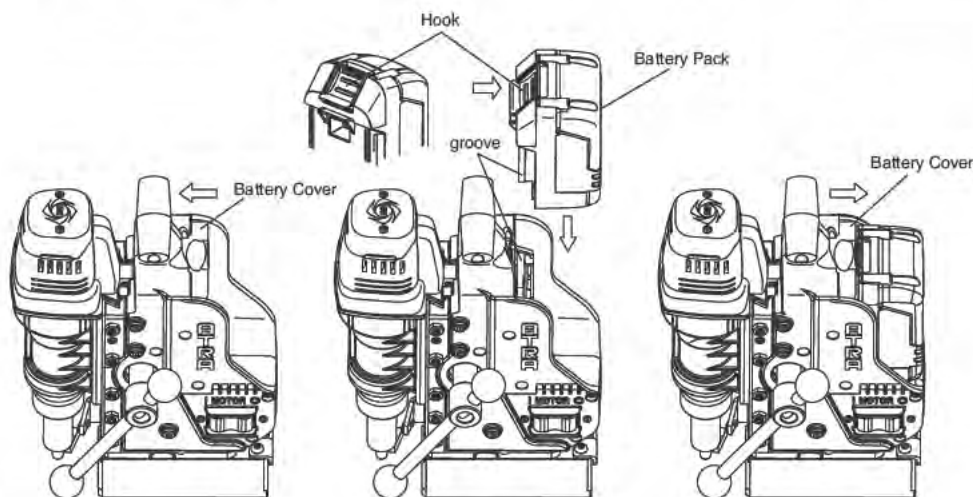

(Fig. 22)

⚠ CAUTION

Be sure to pull out a Battery cover to the Battery pack side after attaching a Battery pack.

If the battery cover is not pulled out to a predetermined position, the electric drill does not operate by the protection circuit.

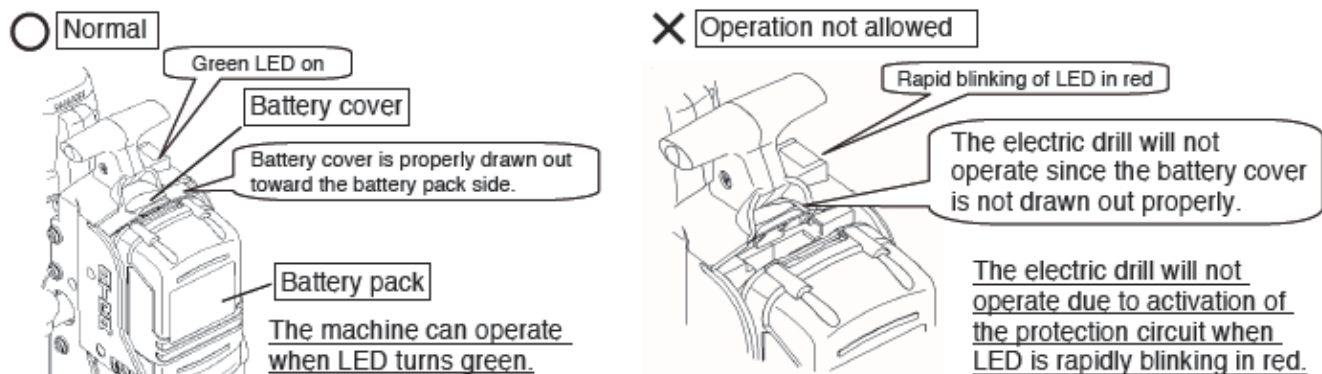

(Fig. 23)

6-9 Detachment of Battery Pack (Fig. 24)

- (1) Check that the magnet switch and electric drill switch are turned off.
- (2) Push the battery cover toward the main body.
- (3) Pull upward the battery pack while pressing the hook

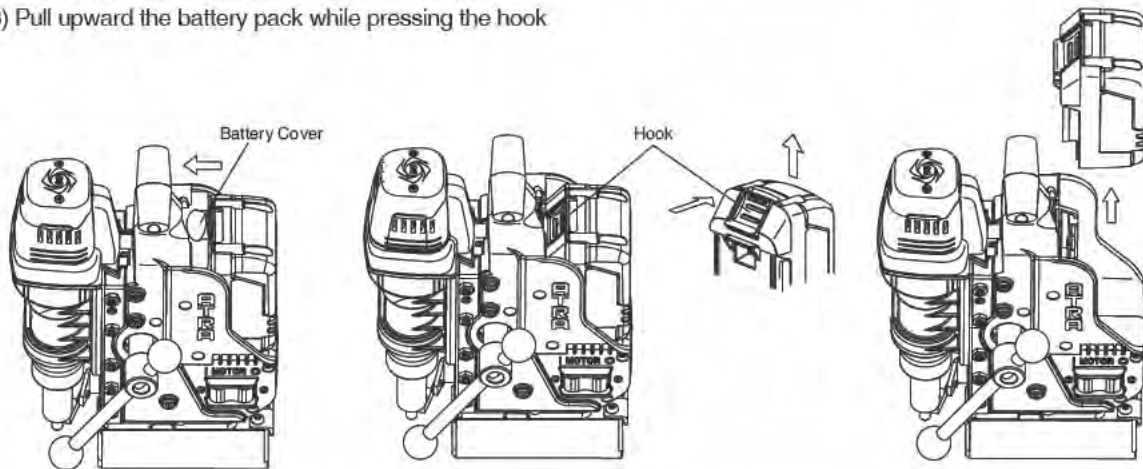

(Fig. 24)

7 MACHINE OPERATION

⚠ WARNING

- Wear the safety goggle while working. If much dust is produced, wear a dust mask.
- Do not wear gloves. Wearing of gloves may cause the hand to be caught in the rotating drill or cutting chips.
- Oil smoke will be generated during the drill by cutting heat. Wear a mask.
- Do not use a hard object such as a screw driver to operate the electric drill switch. It may damage the switch and cause failure.
- Make sure to provide drop prevention to the main body using lashing belt when working in high places or wall surface.

7-1 Start and Stop

⚠ CAUTION

- The electric drill will not rotate when the battery cover is not completely drawn out toward the battery pack. (Fig. 23)
- The electric drill will not rotate with the electric drill switch operation unless the magnet is turned on.

(1) Starting

Magnet switch ON

When the magnet switch is turned on, the magnet starts the adhesion and LED turns white momentarily. After that, LED indicates the remaining power of the battery (blinks three times).

Remaining battery power indication

LED indication	Remaining battery power condition
Green	Approximately fully charged
Yellow	Remaining power has decreased slightly
Red	Remaining power has decreased significantly. Replace the battery pack to a charged battery pack.

: Blink

Electric drill switch ON

When the electric drill switch is turned on, the electric drill starts rotating.

(2) Stop

When the electric drill switch is turned off, the electric drill stops.

Furthermore, when the magnet switch is turned off, the magnetic force of the magnet is released.

7-2 Drilling Procedure

(1) Punching

The punch hole should be vertical with respect to the workpiece and rather large in size. Precisely place the punch hole since it serves as a drilling guide. (Fig. 25)

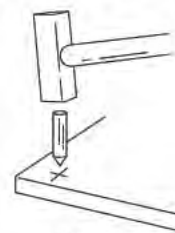

(Fig. 25)

(2) Make sure that both the magnet adhesion surface and the workpiece surface are clean.

⚠ CAUTION

If something is caught under the magnet, there is a danger that the machine may slide off.

Gaps between the magnet adhesion surface and the workpiece weaken the magnetic holding power. Always keep the magnet adhesion surface free from foreign matter (such as metal chips), unevenness, and rust.

(3) Align with punch hole

⚠ WARNING

Make sure that the lock screw to fix body position is securely fastened before drilling.

Loosen the lock screw on the side of the body, and moves the body back and forth or around to align the tip of the pilot pin with the punch. Then tighten the lock screw in the arrow direction.(Fig.26) The lock screw has the wings and is designed to fasten with hands. Do not tighten it with a spanner or the like.

*The lock screw can be mounted on either left or right side of the body.

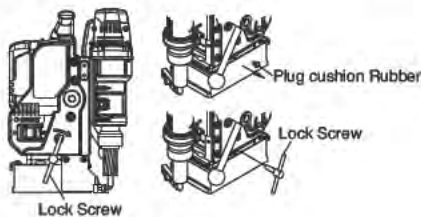

(Fig. 26)

⚠ CAUTION

Remove the plug cushion rubber and attach the lock screw.

Insert the removed plug cushion rubber in the screw hole of the pole plate on the opposite side.

Turn the Handle Ass'y downward to lower the cutter and align the tip of the Pilot Pin with the punch hole. (Fig. 27)



(Fig. 27)

(4) Magnet on

⚠ CAUTION

- Check that the magnet is adhered.
- When energized, the magnet may exhibit a buzzing sound or a slight hum.

Turn the magnet switch on. The magnet starts the adhesion and LED turns white momentarily.

After that, LED indicates the remaining power of the battery (blinks three times).

Remaining battery power indication

LED indication	Remaining battery power condition
Green	Approximately fully charged
Yellow	Remaining power has decreased slightly
Red	Remaining power has decreased significantly. Replace the battery pack to a charged battery pack.

Blink

(5) How to attach the Guard

Please attach the guard as shown in Fig.28.

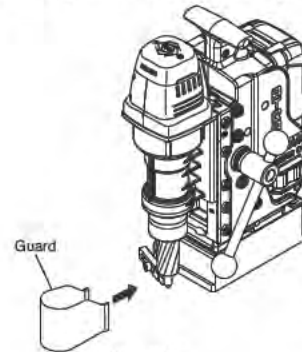

(Fig. 28)

(6) Lubrication

Provide cutting oil using the jet oiler. As a guide, it is desirable to have cutting chips always in wet condition when drilling to prevent burning of cutting chips.

(7) Electric drill switch ON

⚠ WARNING

- Do not touch the rotating area.

Turn the electric drill switch on. The electric drill starts rotating.

Rotate the handle Ass'y and lower the electric drill to start drilling.

(8) Drilling

(8-1) Drilling

Turn the Handle Ass'y downward to start drilling. For the first 2 – 3 mm of the drilling, slowly feed the drill motor. (Fig. 29)

Feed slowly to 2 – 3 mm deep.



Fig. 29

(8-2) Final stage of drilling

⚠ CAUTION

When drilling a hole in an angle, channel or H-section irons, etc., cutter may be damaged when it comes to the slanted part of the work piece on the final cutting stage. Feed slowly in its start and finish cutting. (Fig. 30)

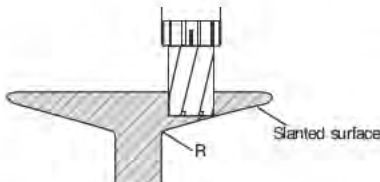

Fig. 30

(9) Finish drilling the hole

⚠ WARNING

- Pay attention to the ejection of slug when finishing the drilling. Never touch slug since the slug is in high temperature and is sharp.
- Make sure that nobody is underneath the work area when working in high places

The machine main body may fall. Also, slug may eject out after drilling. Check that nobody is close to the work area taking dropping of slug into consideration.

Immediately turn the magnet switch off when drilling is completed. Leaving the machine on for an extend period of time leaves electricity flowing in the magnet in which it will shorten the service life of the magnet and the magnetic force will be lost by electric discharge of the battery pack.

(10) Removing slug (Fig. 31)

Do not start drilling the next hole with slug remaining on the drill.

At the end of drilling operation, the pilot pin will be pushed by a spring automatically and slug will be ejected. In a case where slug is left in the drill, remove the slug by tapping the collar of the slug with a needle

stick, etc. since drilling operation cannot be continued when slug is unremoved.

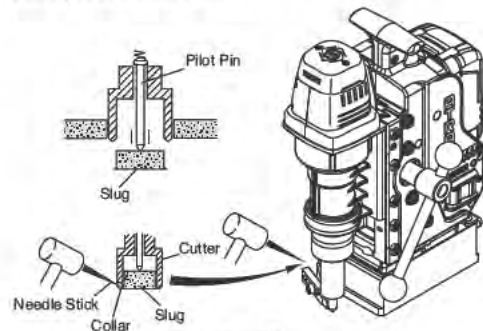

Fig. 31

7-3. Drilling Oblong Hole

⚠ CAUTION

Always drill slowly.

Drill round holes in the order of ①, ②, ③ to get an oblong hole. For the steps ② and ③, take care so that the cutter may not be fed into the work piece with so much force.

File away any remaining excesses. See Fig. 32. Spacing of round holes should be so arranged that the Pilot Pin will always hit the material yet to be machined.

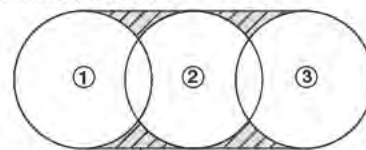

File away any remaining excesses.

Fig. 32

7-4 Drilling H-steel, etc. (Fig. 33)

Remove the blade stay when drilling H-steel, etc. The lock screw may interfere depending on the size of the steel material. Remove the lock screw and use the supplied hexagon socket lock screw 8 x 28 to fix the machine.

Attach the blade stay and lock screw back when the work is completed.

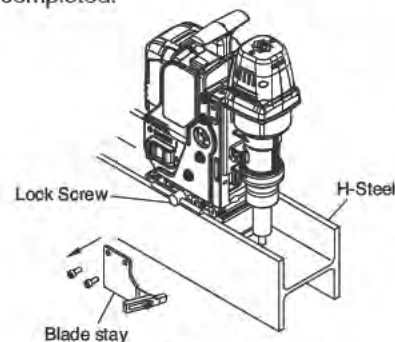

Fig. 33

8 TROUBLESHOOTING

⚠ WARNING

Do not attempt to repair the tool by yourself. This will cause damage to the tool and danger to yourself when you use it again. If any of the following, or other symptoms occur, or if there are other matters concerning usage that you do not understand, please consult the sales agent from whom you purchased the tool or an authorized dealer.

Various errors are indicated by LED with this machine in which the contents of error can be identified by the color of LED. Refer to “4-4 Various Safety Functions and Error Detection Functions” for details including countermeasures for various errors.

9 MAINTENANCE AND INSPECTION

⚠ WARNING

When performing maintenance or inspection work, turn the magnet switch off and remove the battery pack from the machine. Furthermore, unplug the power supply plug of the charger from the electric outlet.

Periodically check for looseness of screws fastened at each part. Tighten the screw if it is loose.

After work, store at a dry area where the temperature is less than 50°C and is out of reach of children.

After work, do not store at an area where volatile that has possibility of ignition or explosion is kept. Do not put conductive items such as chips, nails and copper wires in the storage case.

Attach a terminal cover to the battery pack when storing.

9-1 Greasing of sliding surfaces

From time to time, the sliding surfaces between the body and the Slide Board should be greased.

9-2 Loose Slide Board adjustment

When adjusting looseness of the slide board, check that the slide board is located at the slide board adjustment screw position before tightening.

Any looseness between the body and the Slide Board will adversely affect drilling precision, leading to premature wear on the cutter. When looseness is

encountered, eliminate it by uniformly re-tightening the four Slide Board adjustment screws on the lateral side of the body to the extent that the Drill Motor will not fall under its dead weight. The screws are designed to work as a double-lock, so they should be securely tightened by turning the nuts.

9-3 Sharpening of Pilot Pin tip

If the Pilot Pin tip is dull, the pin will not be able to fit itself into the punching hole, causing poor drilling precision. It should be inspected from time to time, and, if the Pilot Pin tip is found to be dull, sharpen the tip or replace with a new one. Exercise caution during the sharpening operation as any rough grinding softens the tip due to annealing, even to the point of disabling it in some cases. (Fig. 34)

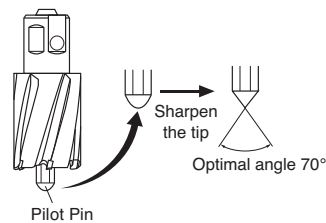

(Fig. 34)

9-4 Loosen a tight Pilot Pin

When the cutter needs to be replaced, pull out and change the Pilot Pin which acts as a guide. However, if Metal chips are caught between the cutter and the pin, the pin may be difficult to be pulled out. Tap the end of the pin gently with a wooden mallet as you pull it out. (Fig. 35)

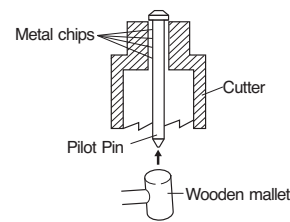

(Fig. 35)

9-5 Cutter grinding

When the cutter needs re-grinding, consult the sales agent from whom you purchased the tool or an authorized dealer.

9-6 Inspection and Replacement of Carbon Brush

Periodically inspect the abrasion condition of the carbon brush.

Replace the carbon brush with a new carbon brush when the remaining length of the carbon brush is 8 to 9 mm since the rectification will deteriorate and may cause machine failure when left unreplaced. (Fig. 36)

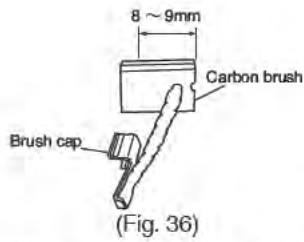

(1) Remove the cross-head tapping screw 3x12 with a Phillips head screwdriver and remove the motor cover. (Fig. 37)

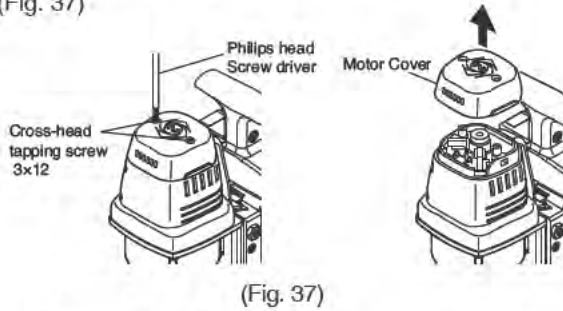

(2) Remove the brush cap of the carbon brush from the brush holder. (Fig. 38)

Remove the brush cap with a tool such as a straight slot screwdriver.

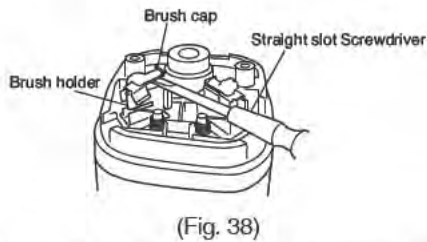

(3) Detach the spring stopper and remove the worn carbon brush. (Fig. 39, Fig. 40 and Fig. 41)

Detach the spring from the brush holder using a straight slot screwdriver and hook it on the brush holder.

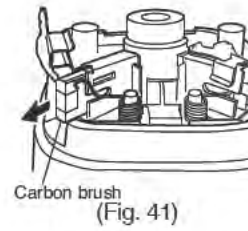
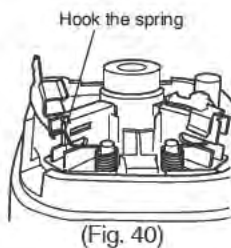
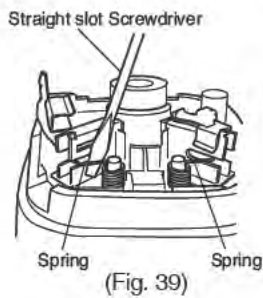

(4) Replace with a new carbon brush. (Fig. 42 and Fig. 43)

*The direction of the carbon brush is specified. Align the pig tail with the groove of the brush holder when attaching.

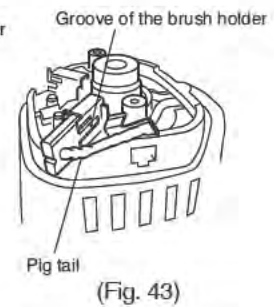
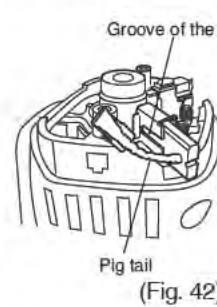

(5) Securely hold the carbon brush with the spring. (Fig. 44)

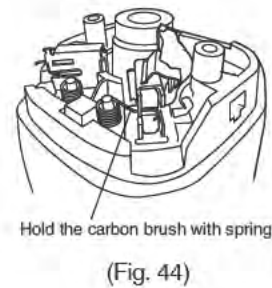

(6) Align the convex area of the brush cap with the oblong hole of the brush holder and securely attach the brush cap. (Fig. 45)

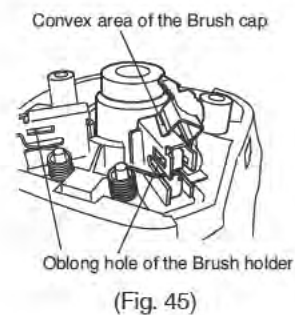

⚠ CAUTION

Pay attention to prevent jamming (hooking) of the lead line (pig tail) with the brush holder when attaching a new carbon brush. (Fig. 46)

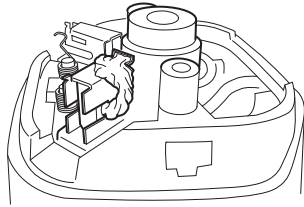

(Fig. 46)

(7) Attach the motor cover and properly fasten using cross-head tapping screw 3 × 12.

*Tightening torque: 1.2 Nm

10 ORDERING SERVICE PARTS

In ordering parts and components from the sales agent from whom you purchased the tool or an authorized dealer, give each part number, parts name and quantity required.

10-1 Genuine Cutting Oil

⚠ CAUTION

Use our Genuine Cutting Oil.

Part No.	Part Name
TB01507	Water-soluble Cutting Oil 2 (Light Blue)

10-2 Pilot Pin

⚠ CAUTION

Whenever you buy a cutter, should also buy a Pilot Pin to suit.

(metric sizes)

Part No.	Part Name	Applicable Cutter
TK01167	Pilot Pin 06025(C1)	Hi-Broach 12 to 17mm dia. Jetbroach 12 to 17mm dia.
TJ12696	Pilot Pin 08025(A1)	Hi-Broach 17.5 to 27mm dia.
TJ15859	Pilot Pin 08035(A2)	Jetbroach 17.5 to 27mm dia.

10-3 Supporting Magnet Ass'y

Part No.	Part Name
TB04374	Supporting Magnet Ass'y

10-4 Oil tank Ass'y

Part No.	Part Name
TB09657	Oil tank Ass'y

10-5 Ordering parts

Jetbroach One-touch Type (metric sizes)

Part No.	Diameter x Depth (mm)	PILOT PIN	Part No.	Diameter x Depth (mm)	PILOT PIN
TK01148	12 X 25	C1	TK00308	21 X 35	A2
TK01149	13 X 25		TK00309	21.5 X 35	
TK01150	14 X 25		TK00310	22 X 35	
TK01151	15 X 25		TK00311	22.5 X 35	
TK01152	16 X 25		TK00312	23 X 35	
TK01153	17 X 25		TK00313	23.5 X 35	
TK00301	17.5 X 35		TK00314	24 X 35	
TK00302	18 X 35	TK00315	24.5 X 35		
TK00303	18.5 X 35	TK00316	25 X 35		
TK00304	19 X 35	TK00317	26 X 35		
TK00305	19.5 X 35	TK00318	26.5 X 35		
TK00306	20 X 35	TK00319	27 X 35		
TK00307	20.5 X 35				

Hi-broach One-touch Type (metric sizes)

Part No.	Diameter x Depth (mm)	PILOT PIN	Part No.	Diameter x Depth (mm)	PILOT PIN
TK00698	12 X 25	C1	TK00341	21.5 X 25	A1
TK00699	13 X 25		TK00342	22 X 25	
TK00700	14 X 25		TK00343	22.5 X 25	
TK00701	15 X 25		TK00344	23 X 25	
TK00702	16 X 25		TK00345	23.5 X 25	
TK00703	17 X 25		TK00346	24 X 25	
TK00335	17.5 X 25		TK00347	24.5 X 25	
TK00336	18 X 25	TK00348	22 X 25		
TK00337	19 X 25	TK00349	26 X 25		
TK00338	19.5 X 25	TK00350	26.5 X 25		
TK00339	20 X 25	TK00351	27 X 25		
TK00340	21 X 25				

11. RECYCLE

Lithium-ion batteries are required to be recycled; never discard a lithium-ion battery in the trash. Please contact your local sales office or community recycling program for information on properly disposing of lithium-ion batteries.

12 ATRA ACE CLA-2720 ASSEMBLY

WARNING

This diagram is for reference only. Do not attempt to service or repair the Nitto Portable Magnetic Drilling Machine. Do not take the machine apart. Contact an authorized Nitto dealer for all service and repair of the machine. Improper service and repair can cause accidents and severe injuries. Never attempt to modify the machine. Never attempt to service or repair the machine yourself.

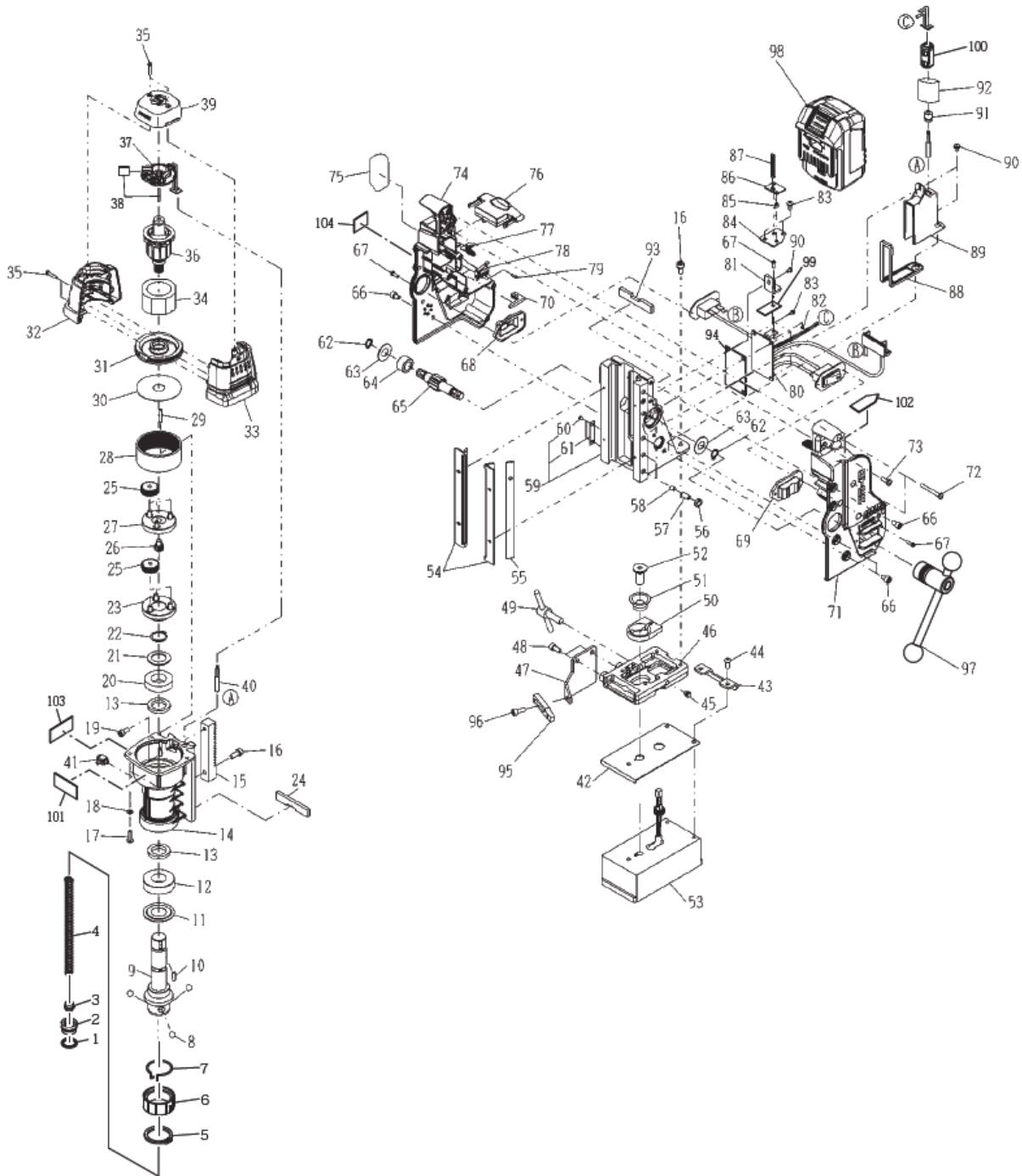

13 ATRA ACE CLA-2720 PARTS LIST

The part numbers with () are included in the Ass'y parts written above them.

No.	Part No.	Part Name	Q'ty	Price
1	TQ10547	Y Packings NB-15X19X1	1	
2	TB07598	Push Ring Ass'y	1SET	
3	TQ11343	Pilot Spacer	1	
4	TQ14109	Spring 1.2X11X100	1	
5	TP15239	External Retaining Ring C- 28	1	
6	TQ01897	Sleeve	1	
7	TQ01896	Rotating Spring	1	
8	TP06633	Ball 5/16 (7.938)	3	
9	TQ14118	Arbor	1	
10	TQ10570	Parallel Key Both Ends Round 4X4X12	1	
11	TQ14114	Bearing Cover	1	
12	TP16155	Ball Bearing 6004LLB	1	
13	TQ14121	Oil Seal AG0994E1	2	
14	TQ14095	Gear Case	1	
15	TQ14104	Rack	1	
16	TQ03329	Hex. Socket Head Cap Screw 5X15	5	
17	TQ14153	Pan Head Tapping Screw #2 B-0 4X16	4	
18	TP00244	Spring Washer M 4	4	
19	TP00021	Hex. Socket Head Cap Screw 5X10	1	
20	TQ14124	Ball Bearing 6904LLU	1	
21	TQ14111	Washer 19.7X30.5X1.6	1	
22	TQ05265	External Retaining Ring C- 19	1	
23	TB09481	Gear Base B Ass'y	1SET	
24	(TQ14120)	Dowel Pin C type 5X15	3	
25	TQ14097	Idle Gear	6	
26	TQ14100	Sun Gear	1	
27	TB09480	Gear Base A Ass'y	1SET	
24	(TQ14120)	Dowel Pin C type 5X15	3	
28	TQ14102	Ring Gear	1	
29	TQ14125	Parallel Pin typeB 2.5X20	1	
30	TQ14113	Gear Cover	1	
31	TQ14106	Motor Flange	1	
32	TQ14127	Motor Case A	1	
33	TQ14128	Motor Case B	1	
34	TB09318	Stator Ass'y	1SET	
35	TQ14163	Pan Head Tapping Screw type2 B-0 3X15	6	
36	TB09485	Armature with Gear Ass'y	1SET	
37	TB09504	Brush Holder with PCB Ass'y	1SET	
38	TB09316	Carbon Brush Ass'y	1SET	
39	TQ14126	Motor Cover	1	
40	TB09704	Reray Cord Ass'y	1SET	
41	LQ00612	Universal Elbow UEF6	1	
42	TQ14117	Pole seat	1	
43	TQ14149	Belt Attachment Plate	1	
44	TQ14151	Hex. Socket Button Head Screw 5X12	2	
45	TQ14162	Plug Cushion Rubber	1	
46	TB09479	Pole Plate Ass'y	1SET	
47	TQ14155	Blade Stay	1	
48	TP01644	Hex. Socket Head Cap Screw 6X12	2	
49	TB07068	Lock Screw Ass'y	1SET	
50	TQ10348	Lock Plate	1	
51	TQ10347	Radial Shaft	1	
52	TP14176	Hex. Socket Countersunk Head Screw 10X25	1	
53	TB09495	Square Pole with Pin Ass'y	1SET	
54	TP15103	Slide Plate	2	
55	TQ14193	Gib	1	
56	TP07419	Hex. Nut M 6 type3	5	
57	TQ14150	Hex. Socket Set Screw With Flat Point 6X12	5	
58	TQ04783	Supporter	5	
59	TB09490	Body Sub Ass'y	1SET	
60	(TP05136)	Drive Rivet No.2x4.8	2	
61	(TQ10804)	Plate Serial Number	1	

No.	Part No.	Part Name	Q'ty	Price
62	TP06390	External Retaining Ring C- 11	2	
63	TQ14110	Washer 11.2X24.5X1	2	
64	TQ14105	Sleeve	1	
65	TQ14103	Pinion Shaft	1	
66	TP00200	Hex. Socket Head Cap Screw 5X 8	8	
67	TQ02129	Pan Head Screw 3X10 with Spring Washer	5	
68	TQ14134	Switch Cover WHITE	1	
69	TQ14135	Switch Cover RED	1	
70	TQ14136	Seal Bushing A	1	
71	TQ14133	Housing B	1	
72	TQ14154	Pan Head Tapping Screw type2 B-0 4X35	6	
73	TQ14152	Pan Head Tapping Screw type2 B-0 4X12	1	
74	TB09484	Housing A Ass'y	1SET	
75	TQ14303	Label Specification	1	
76	TQ14129	Battery Cover	1	
77	TB09497	LED PCB Ass'y	1SET	
78	TB09500	Limit Switch Ass'y	1SET	
79	TQ14197	Pan Head Tapping Screw type2 B-0 2.3X12	2	
80	TB09496	Control Board Ass'y	1SET	
81	TQ14116	Heat Radiation Plate	1	
82	TP00067	Hex. Nut M 3 type1	1	
83	TP06290	Pan Head Screw 4X8 with Spring Washer	5	
84	TQ14115	Plate for Sensor PCB Ass'y	1	
85	TV01343	Spacer	2	
86	TB09498	Sensor PCB Ass'y	1SET	
87	TB09501	HarnessSensor Ass'y	1SET	
88	TQ14137	Seal Bushing B	1	
89	TQ14130	Cable Box	1	
90	LP31234	Pan Head Screw 4X10 with Spring Washer	3	
91	TQ14138	Cord Bushing	1	
92	LQ05330	Insulation Tube F(Z) dia.20mm	0.04M	
93	TQ14165	Packing Body	1	
94	TQ14166	Packing Gear Case	1	
99	TQ14278	Insulation sheet	1	
100	TQ14331	Clamp Filter (ZCAT1325-0530A)	2	
101	TQ14304	Label Arbor Warning	1	
102	TQ14468	Label Battery Cover	1	
103	TQ14460	Label Guarantee (AUSTRALIA)	1	
104	LQ04642	Label RCM (AUSTRALIA)	1	

Accessories

No.	Part No.	Part Name	Q'ty	Price
	TB01377	Soluble Cutting Oil 0.5 Ass'y	1SET	
98	TB09824	Battery Pack 18V NBL18006	2SET	
97	TB09482	Handle Ass'y	1SET	
	TB09702	Carry Case Ass'y	1SET	
	TP01939	Hex. Socket Screw Key 4	1	
96	TP01945	Hex. Socket Head Cap Screw 5X12	1	
	TP04696	Hex. Socket Screw Key 3	1	
	TP16070	Tube 4X7	1M	
	TP17014	Spanner 8X10	1	
	TQ10075	Lashing Belt BLC002R-015	1	
	TQ10489	Hex. Socket Set Screw 8X28	1	
	TQ10581	Jet oiler NO.3013	1	
95	TQ10787	Blade	1	
	TQ14330	Instruction Manual	1	
	TB09825	Battery Charger NC14435	1SET	
	TB09806	Battery Charger NC14435 (AUSTRALIA)	1SET	
	TQ14333	Guard	1	



Overseas Affiliates / Offices

NITTO KOHKI U.S.A., INC.
46 Chancellor Drive, Roselle, IL 60172 U.S.A.
Tel:(1)-630-924-9393 Fax:(1)-630-924-0303

NITTO KOHKI EUROPE CO., LTD.
UNIT A5, LANGHAM PARK, MAPLE ROAD,
CASTLE DONINGTON,
LEICESTERSHIRE DE74 2UT, U.K.
Tel:(+44)-1332-653800 Fax:(+44)-1332-987273

NITTO KOHKI DEUTSCHLAND GMBH
Lerchenstr.47 D-71144 Steinenbronn, Germany
Tel:(49)-7-157-22436 Fax:(49)-7-157-22437

NITTO KOHKI CO., LTD., SINGAPORE BRANCH
10 UBI CRESCENT #01-62,
UBI TECHPARK LOBBY D, SINGAPORE 408564,
Tel:(65)-6227-5360 Fax:(65)-6227-0192

NITTO KOHKI AUSTRALIA PTY. LTD.
77 Brandl St., Brisbane Technology Park,
Eight Mile Plains QLD 4113 Australia
Tel:(61)-7-3340-4600 Fax:(61)-7-3340-4640

**NITTO KOHKI CO., LTD.,
BANGKOK REPRESENTATIVE OFFICE**
M&A Business Center 38Q, House Convent Bldg.,
7th Floor, Unit 7A, Convent Rd., Silom, Bangrak,
Bangkok 10500 Thailand
Tel:(66)-2-632-0307 Fax:(66)-2-632-0308

NITTO KOHKI (SHANGHAI) CO., LTD.
Room1506, suite C, Orient International Plaza,
NO85 LouShanGuan Road, Shanghai, 200336, CHINA
Tel:(86)-21-6415-3935 Fax:(86)-21-6472-6957

**NITTO KOHKI CO., LTD.,
SHENZHEN REPRESENTATIVE OFFICE**
2005C Shenzhen ICC Tower, Fuhuasanlu 168, Futian District,
Shenzhen, Guangdong, 518048 China
Tel:(86)-755-8375-2185 Fax:(86)-755-8375-2187

EC DECLARATION OF CONFORMITY

We hereby declare that the following our product conforms with the essential health and safety requirements of EC Directives.

Product: PORTABLE MAGNETIC DRILLING MACHINE

Model: ATRA ACE : CLA-2720,NC14435

Serial No: In the case of 6 digits serial number.

X X X X X X

→ Consecutive numbers (00001~99999)

→ Last digit (0-9) of year (A.D.)

In the case of 7 digits serial number.

X X X X X X X

→ Consecutive numbers (00001~99999)

→ Last digit (00-99) of year (A.D.)

Manufacturer: NITTO KOHKI Co., Ltd.
2-9-4, Nakaikegami, Ohta-ku, Tokyo, 146-8555, Japan

Authorized person to prepare the technical construction file(TCF) in the community:

Masatoshi Ogue

President

NITTO KOHKI EUROPE Co., Ltd.

Unit21, Empire Centre, Imperial Way, Watford

Hertfordshire, WD24 4TS, UK

Tel:(44)-01923-239668 Fax:(44)-01923-248815

Directive: 2006/42/EC Machinery Directive
2006/95/EC Low Voltage Directive
2014/30/EC EMC Directive
2011/65/EU RoHS Directive

The above product has been evaluated for conformity with above directives using the following European standards. The technical construction file (TCF) for this product is retained at the above manufacturer's location.

Machinery Directive: EN 60745-1:2009+A11:2010, EN 60745-2-1:2010

Low Voltage Directive: EN 60335-1:2002 +A1:2004 +A2:2006

EN 60335-2-29:2004 +A1:2004 +A2:2010, EN 62233:2008

EMC Directive EMI: EN55014-1:2006+A1:2009+A2:2011

EMS: EN55014-2:1997+A1:2001+A2:2008

RoHS Directive: EN50581:2012

Signature: _____

Date/Place: _____ /Tokyo, Japan

Name: Katsunobu Kishi

Title: General Manager MACHINE TOOLS Business Div.

NITTO KOHKI Co., Ltd.

2-9-4, Nakaikegami, Ohta-ku, Tokyo, 146-8555, Japan

Being the responsible person appointed and employed the manufacturer.