



Established 1930

Distributors of new & used workshop Equipment

W795

OVS-JM
BOBBIN SANDER

INSTRUCTION & PARTS MANUAL

17-6-11

OVS-JM

OSCILLATING VERTICAL SPINDLE SANDER

FEATURES

- The rubber drum can be fitted on both ends to fully utilize the entire spindle.
- The oscillating sanding provides an extremely fine sanding finish.
- Ten sanding drums can be accommodated.
- Easily interchanged spindles.
- The tilting table is precision ground.
- Heavy gauge steel frame.

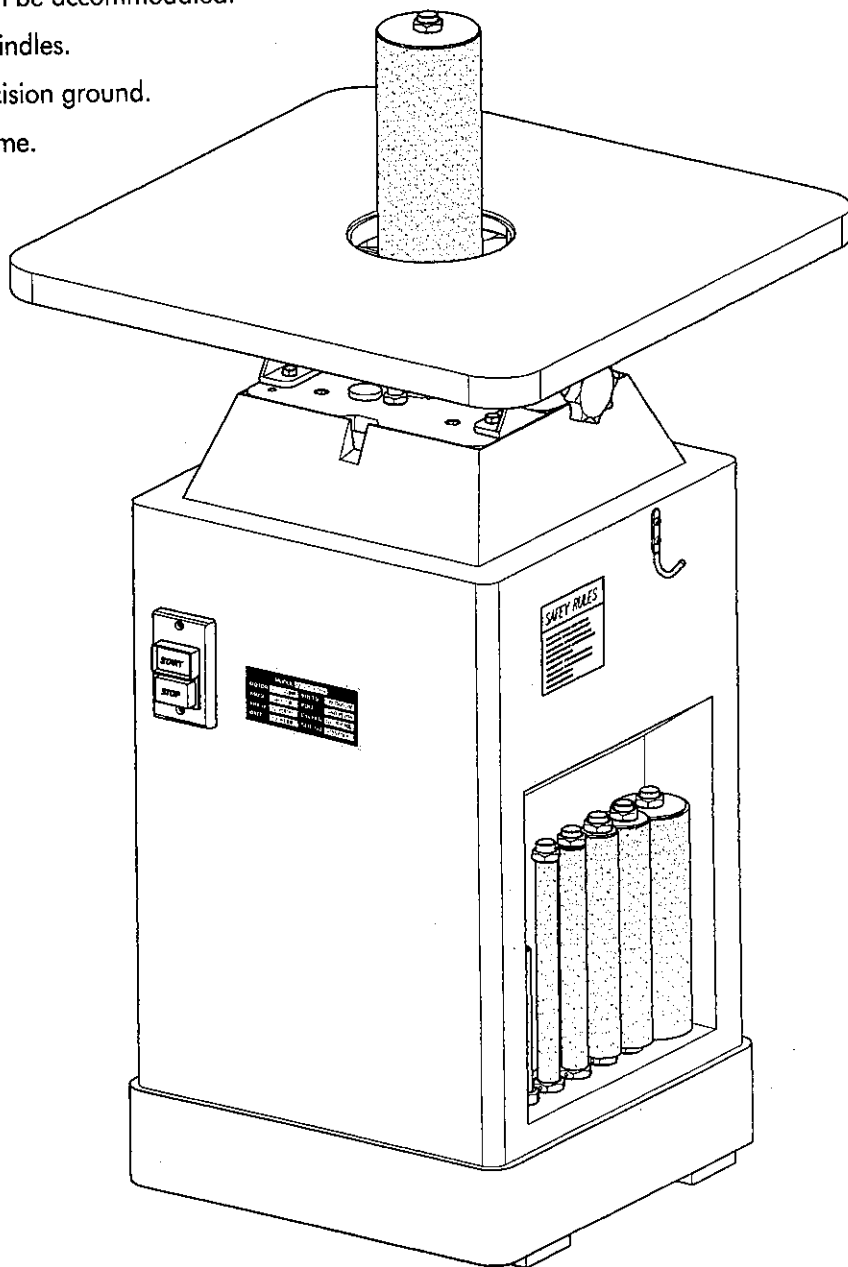

SAFETY RULES

READ CAREFULLY BEFORE OPERATING THE MACHINE

1. Learn the machine's applications and limitations, as well as the specific potential hazards particular to this machine. Follow available safety instructions and safety rules carefully.
2. Keep working area clean and be sure adequate lighting is available.
3. Do not wear loose clothing, gloves, bracelets, necklaces, or ornaments. Wear face, eye, ear, respiratory and body protection devices, as indicated for the operation or environment.
4. Keep hands well away from cutter head and all moving parts. Do not clear chips and sawdust away with hands. Use a brush.
5. Make sure the spindles are moving at operation speed before sanding.
6. Do not push the sanding spindles to hard. The spindles will perform better and be safer working at the rate for which it was designed.
7. Whenever possible use a dust collector with shaving hood to minimize health hazards.
8. Never leave the machine with the power on.
9. Keep children away. Make sure that visitors are kept at a safe distance from the work area.
10. Use recommended speed sanding accessory, and workpiece material.
11. Never stand on tool. Serious injury could occur if the tool is tipped or if the sanding tool is unintentionally contacted.
12. Be sure sanding spindles are securely locked in the machine.
13. Use suitable support if stock does not have a flat surface.
14. Do not force the machine. It will do the job better and be safer at a rate for which it was designed.
15. Keep guards in place and in working order. If a guard must be removed for maintenance or cleaning make sure it is properly attached before using the tool again.
16. Be sure that key and adjusting wrenches have been removed before turning power on.
17. Use only accessories designed for the machine.
18. Make sure tool is properly grounded. If tool is equipped with three-prong plug, it should be plugged into a three-pole electrical receptacle. Never remove the third prong.
19. Always disconnect tool before servicing and when changing accessories such as spindle sizes.
20. Make sure that switch is in "OFF" position before plugging in cord.
21. Hold material firmly against the table.
22. Use ONLY recommended accessories. Use of accessories NOT recommended by may result in a risk of injury.
23. Do not use this spindle sander for other than it's intended use. If used for other purposes, disclaims any real or implied warranty and holds itself harmless for any injury, which may result from that use.

OVS—JM spindle sanders are carefully tested and inspected before shipment and if properly used it will give perfect results. However, a reasonable amount of care and attention is necessary to ensure perfect performance and accurate work. It is imperative that you take a few moments to familiarise yourself with these instructions, as they will no doubt save you a lot of time and trouble.

MODEL OVS—JM SPINDLE SANDER **OSCILLATING VERTICAL**

1. This machine has been designed for grinding, or polishing curves, and surfaces of wood, plastic, or metal materials.
2. For process of irregular round curve workpieces, the machine provides an optional bench for adjustment to any degree of angle.
3. To keep machine and parts in perfect condition, change oil lubricant after every 800 hours of operation.
4. Caution the machine is equipped with ten sanding arbors, three round inserts and two open spanners, install them carefully and properly to avoid any cutting damage.
5. When selecting a sanding arbor, it should depend on the size of the round curve of the polished workpiece. The sanding arbor should be smaller than the curve of the polished workpiece.
6. It is recommended to mark on the workpiece before moulding, to ensure that while in process it follows your marks to give precise and correct results. **NOTE** Never attempt to ground or cut the workpiece with the powerful sanding arbor to achieve correctness and preciseness.
7. Clean the sanding arbor and the main shaft hole, before inserting the sanding arbor into the main shaft. **NOTE:** Never screw the sanding arbor tightly, otherwise it could not be taken off.
8. After every use of the machine, clean and polish all parts. Polish bench with specialised oil, always re-adjust bench to proper position of 90° angle.

ATTENTION !
Before operating this machine, have all workers and operators read this manual attentively! Avoiding this procedure can cause serious damage to machine and risk putting the worker or operator in a dangerous situation!

UNPACKING AND CLEAN UP

To ensure maximum performance from your OVS—JM spindle sander, clean it properly; and install it accurately before use. As soon as you receive the spindle sander, we recommend you follow these procedures:

1. Finish removing the contents of the shipping carton and compare with the contents list.
2. Report damage, if any to your local distributor.
3. Clean all rust protected surfaces with a mild solvent or kerosene. Do not use lacquer thinner, paint thinner, or gasoline. These will damage painted surfaces.
4. To prevent rust, apply a light coating of paste wax to surface.

WARNING !

Never attempt to clean machine when it is plugged into the power source! Ignoring this procedure can cause damage to your machine, and will put the worker in dangerous situation!

MAINTENANCE OF SPINDLE SANDER

1. To keep your spindle sander in perfect condition, clean machine and attachments at all times.
2. Clean tapered sleeves and tapered socket before every use, this will protect spindle sleeves from nicks.
3. Bent sleeves are easily straightened by placing them in the tapered socket and slipping a small pipe over the steel shaft. Using a dial indicator check that it is in correct position.
4. Check gearbox for proper oil level (Approx. $\frac{1}{4}$ up on sight glass).
5. We recommend that a small amount of grease be applied to table tilting screw once a month.
6. No lubrication is required for the bearings, they are permanently lubricated.

INSTRUCTIONS FOR OPERATIONS

1. Select a spindle that is smaller than the curve to be sanded.
2. Use an insert plate that comes closest to the spindle without touching it.
3. Make sure that spindle is properly positioned in taper sleeve socket. With the wrench provided, tighten the nut. **NOTE:** Never overtighten, it may be difficult to remove the spindle later.
4. When table is set at a 90° angle, sanding may be done from any corner, or location on table around spindle.
5. When table is positioned at any angle other than 90°, it is necessary to position the work piece over the centerline, as shown on table surface.
6. Always lock the table with the hand nut when setting at any angle, also to prevent movement lock the tilting gear shaft.
7. Always loosen both table lock and tilting gear lock before changing the angle position of the table. Never force the table if it does not tilt easily, reason may be that the locks are still engaged. Never attempt to over ride the stop locks, this will cause damage to the tilting performance.
8. A backing board is recommended when sanding thin pieces of metal or any other material. A backing board can be easily constructed by using a piece of wood the length of the table, pushing it into the spindle until a half circle is formed. Clamp each end of the board to the table and proceed to sand the thin material.
9. Before leaving the machine remove any particles or pieces left over, always-return table to a 90° angle.

CONNECT THE FLEXIBLE HOSE

The machine is furnished with a dust hood under the table at the back side of the machine. The outlet of the dust hood is 4" in diameter. Use a 4" flexible hose to connect the dust hood outlet to the dust collector.



CAUTION:

Do not operate the machine until the dust collector is working.

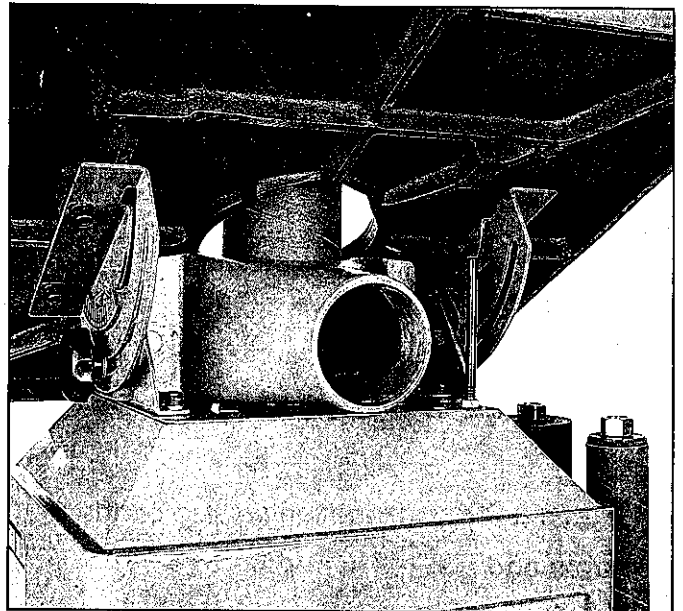

TILTING THE TABLE

1. Loosen the two table lock knobs (A), located under the table at both sides of the machine.
2. Tilt the table forward to the desired angle with your hands.
3. An angle scale is provided at the right side of the trunnion to indicate the degree of table tilt.
4. Tighten the two table lock knobs securely after the table degree has been adjusted.

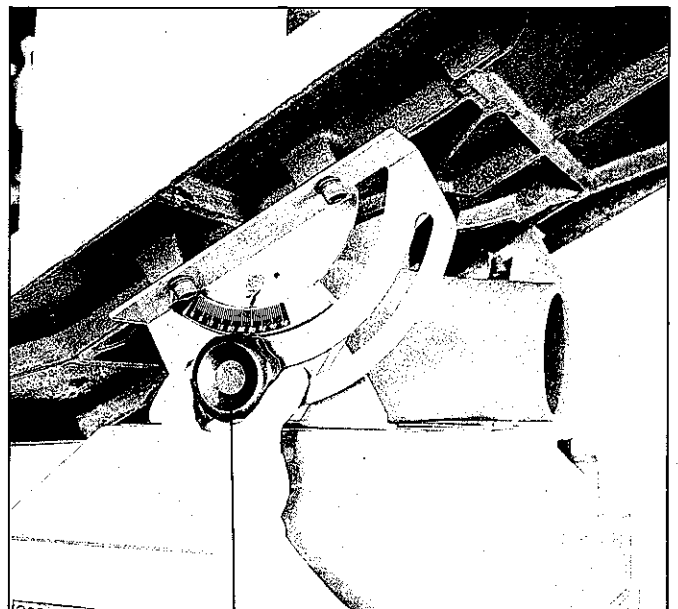

A

ADJUST THE SQUARENESS BETWEEN THE TABLE AND DRUM

1. The squareness between the table and drum has been factory adjusted before shipment. However, after a long period of operation, the squareness may become inaccurate.
2. To adjust the squareness, set the table to a flat horizontal position. The table tilting scale should read zero degrees.
4. Place a 90° combination square on the table and against the drum.
5. If the table is not 90° from the drum, adjust the angle of the table by changing the height of the resting post as shown.
5. If the table is 90° from the drum, but the scale does not read zero degrees, set the scale to read zero degrees by loosening the screw on the angle indicator and setting the arrow to zero.

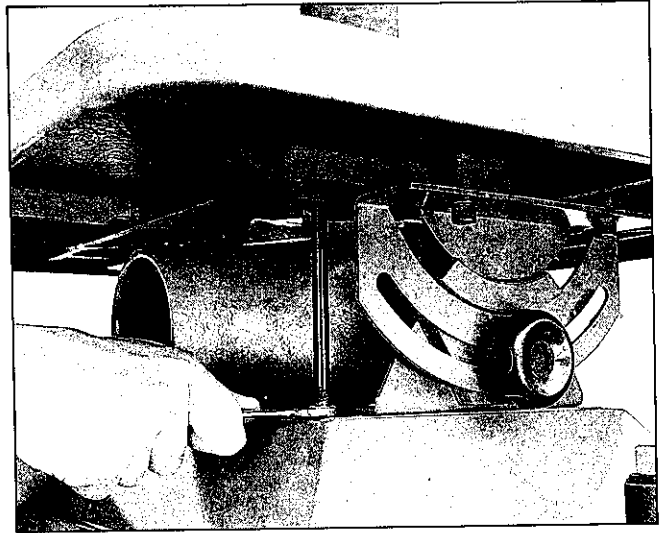

LOOSE PARTS BAG

Sanding drums 10 pcs

Table inserts 3 pcs

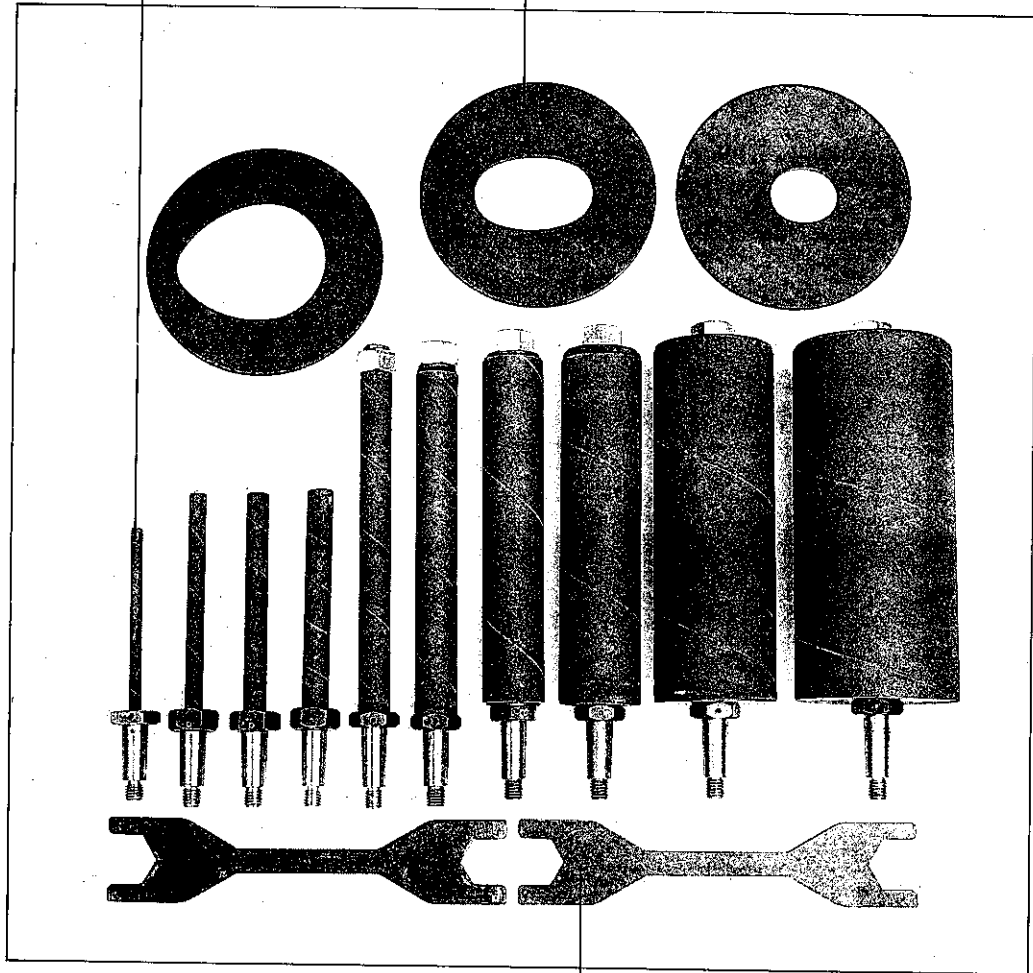

Open end wrench 2 pcs

SELECTION GUIDE FOR DRUM TO TABLE INSERT

This machine is furnished with 10 drums. Range of drum diameter is 1/4" to 4". Three table inserts are supplied. If the drum diameter is changed, the table insert needs to be changed to the appropriate size.

The table below shows which table insert to use for various drum diameters

⚠ WARNING!
Failure to use the correct insert with the corresponding drum may result in injury!

Drum Diameter	Table Insert
#1 1/4" Dia. x 5" long	#1
#2 3/8" Dia. x 6" long	#1
#3 1/2" Dia. x 6" long	#1
#4 5/8" Dia. x 6" long	#1
#5 3/4" Dia. x 9" long	#1
#6 1" Dia. x 9" long	#2
#7 1 1/2" Dia. x 9" long	#2
#8 2" Dia. x 9" long	#3
#9 3" Dia. x 9" long	None
#10 4" Dia. x 9" long	None

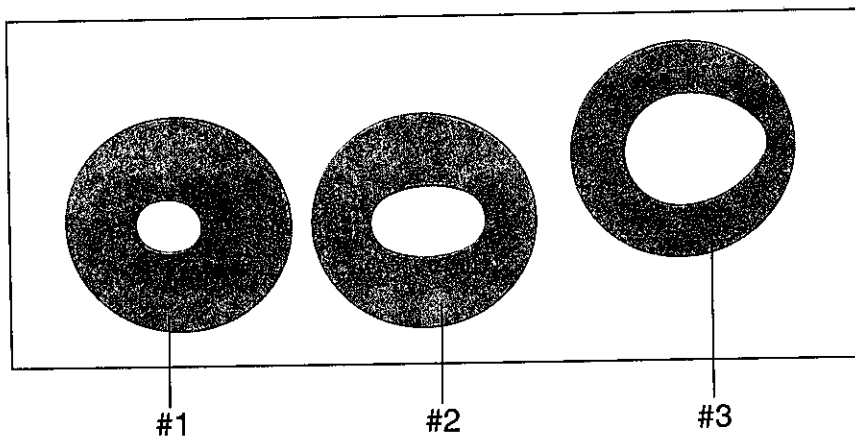

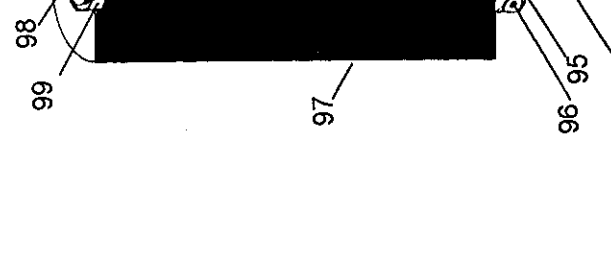
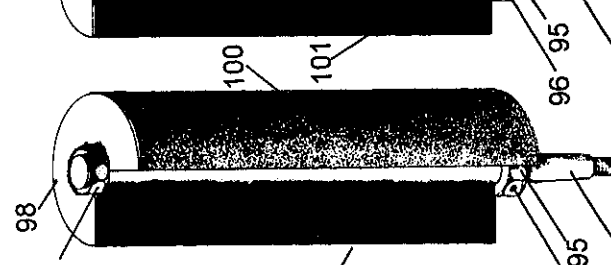
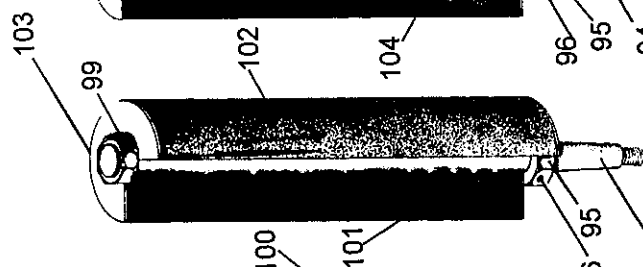
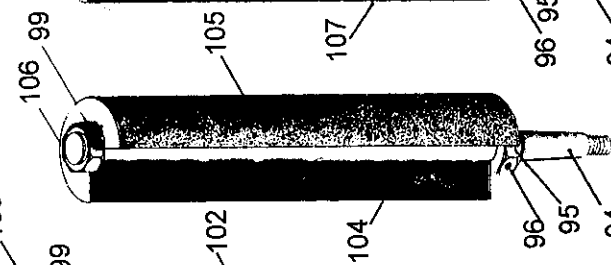
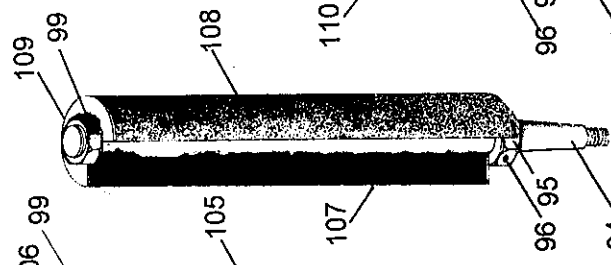
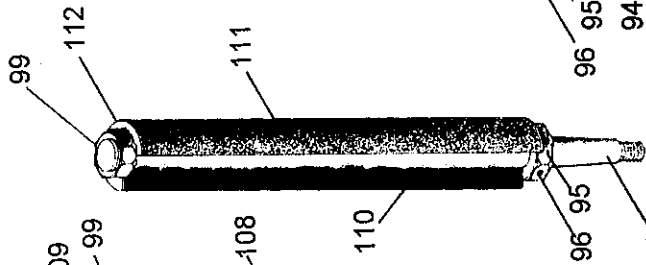
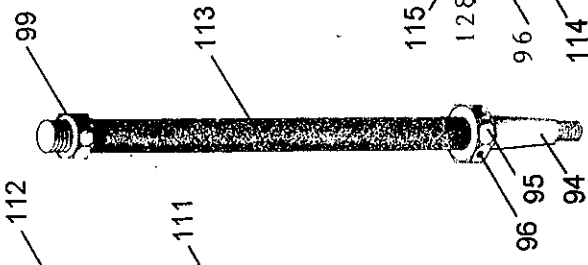
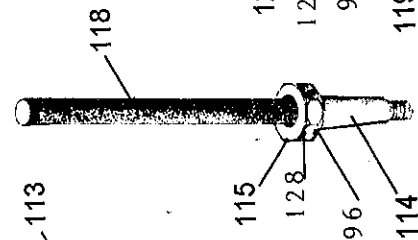
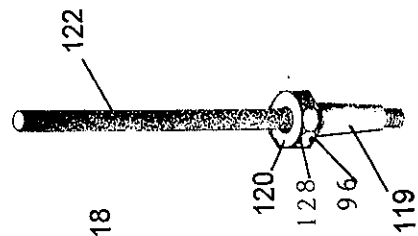
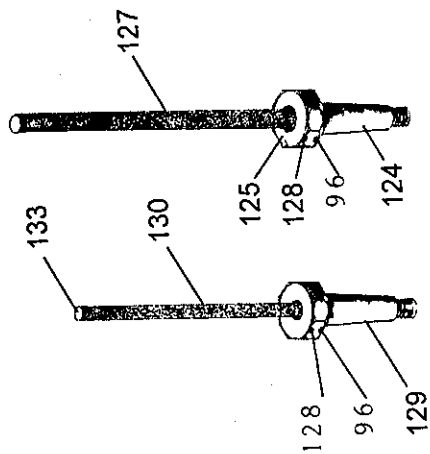
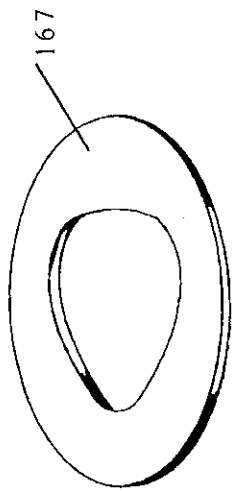
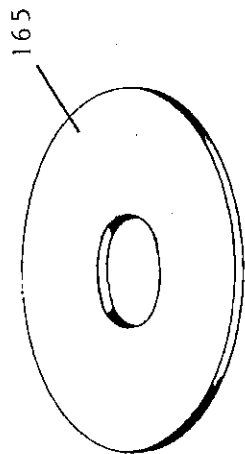
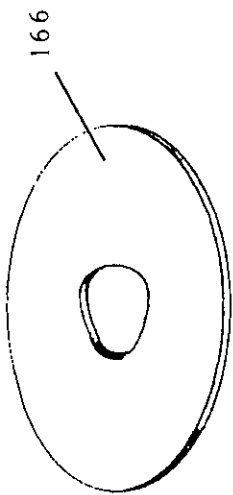
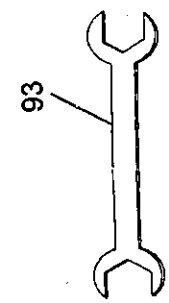

**Parts List for the OVS-JM
Oscillating Vertical Spindle Sander**

PART No.	REFERENCE No.	DESCRIPTION	QTY.
7	L0000000	Power Cord	1
11	S0400525	Key	1
18	30101011	Oil Indicator	1
20	30101014	Oil Seal	1
21	C1206206	Ball Bearing	1
22	S0526500	C Snap Ring	2
26	30103014	Sleeve	1
27	30103015	Guide Rail Shaft	1
28	C1206205	Ball Bearing	2
29	30103016	Locking Nut	1
30	30103017	Worm	1
31	S0310530	Spring Pin	1
32	30103018	Main Shaft	1
33	S0400550	Key	1
34	S0010210	Set Screw	1
35	30103019	Spur Gear	1
36	30103020	Brass Bushing	2
37	S0010501	Hex Socket Cap Screw	4
38	30103021	Transmission Rod Shaft	2
39	30103022	Transmission Rod	2
40	S0110600	Locking Nut	4
47	L0000000	Switch Cord	1
52	S0110503	Locking Nut	1
55	30101029	Rear Trunnion Bracket	2
56	S0010510	Hex Screw	6
64	30101035	Oil Lid	1
66	S0010610	Hex Socket Cap Screw	4
67	S0210600	Washer	4
86	40301032	Width Pointer	1
87	S0030304	Screw	1
88	30101049	Cap	1
89	30101050	Nut	2
93	30105054A	Wrench	2
94	30105055	Arbor	6
95	30105056	Hex Nut	6
96	S0313525	Spring Pin	10
97	30105057	P.V.C	1
98	30105058	Washer	2
99	30105059	Nut	6
100	30105060	Sanding Cloth	1
101	30105061	P.V.C	1

**Parts List for the OVS- JM
Oscillating Vertical Spindle Sander**

PART No.	REFERENCE No.	DESCRIPTION	QTY.
102	30105062	Sanding Cloth	1
103	30105063	Washer	2
104	30105064	P.V.C	1
105	30105065	Sanding Cloth	1
106	30105066	Washer	2
107	30105067	P.V.C	1
108	30105068	Sanding Cloth	1
109	30105069	Washer	2
110	30105070	P.V.C	1
111	30105071	Sanding Cloth	1
112	30105072	Washer	2
113	30105073	Sanding Cloth	1
114	30105074	Arbor	1
115	30105075	Hex Nut	1
118	30105076	Sanding Cloth	1
119	30105077	Arbor	1
120	30105078	Hex Nut	1
122	30105079	Sanding Cloth	1
124	30105080	Arbor	1
125	30105081	Hex Nut	1
127	30105082	Sanding Cloth	1
128	S0050305	Screw	4
129	30105083	Hex Nut	1
130	30105084	Sanding Cloth	1
133	30105085	Arbor	1
134	30101004	Oil Plug	1
135	30105087	Brass Bushing Bracket	1
136	30105088	Shaft Brass Bushing	4
137	30101005	Knob	1
138	S0010510	Screw	4
139	30101030a	Bracket Base	2
140	S0210500c	Washer	4
141	S0020510	Screw	6
142	10105052n	Switch Box	1
143	S0030324	Screw	3
143a	S0110300	Nut	3
144	30101002j-1	Vent Hood	1
145	30101002JM	Column	1
146	30101003a	Motor Bracket	1
147	M3131211E	Motor	1
148	S1006P1	Strain Relief Bushing	1

**Parts List for the OVS- JM
Oscillating Vertical Spindle Sander**

PART No.	REFERENCE No.	DESCRIPTION	QTY.
149	S0230506	Spring Washer	8
150	S0010501	Hex Screw	12
151	30102008a	Coupling Head	1
152	30101009a	Tank Lid	1
153	S0050404	Set Screw	2
154	30101013a	Tank Lid	1
155	W0000001	Switch	1
157	S0210600	Washer	4
158	30101033a	Rear Trunnion	2
159	30101031j	Locking Knob	2
160	30101034a	Dust Cover	1
161	S0020501	Hex Screw	2
162	S0110500	Nut	2
163	30101036a	Working Table	1
164	30101047a	Scale	1
165	30105051a	Table Insert (medium)	1
166	30105052a	Table Insert (small)	1
167	30105053a	Table Insert (Large)	1
169	30101027a	Fixed Rod	1
170	S0110600	Nut	1
171	10401029	Rubber Feet	4
172	S0030512	Sinking Head Screw	4
173	S0110500	Nut	4
174	J3010001	Logo	1

WARNING

General Machinery Safety Instructions

Machinery House
requires you to read this entire Manual before using this machine.

- 1. Read the entire Manual before starting machinery.** Machinery may cause serious injury if not correctly used.
- 2. Always use correct hearing protection when operating machinery.** Machinery noise may cause permanent hearing damage.
- 3. Machinery must never be used when tired, or under the influence of drugs or alcohol.** When running machinery you must be alert at all times.
- 4. Wear correct Clothing.** At all times remove all loose clothing, necklaces, rings, jewelry, etc. Long hair must be contained in a hair net. Non-slip protective footwear must be worn.
- 5. Always wear correct respirators around fumes or dust when operating machinery.** Machinery fumes & dust can cause serious respiratory illness. Dust extractors must be used where applicable.
- 6. Always wear correct safety glasses.** When machining you must use the correct eye protection to prevent injuring your eyes.
- 7. Keep work clean and make sure you have good lighting.** Cluttered and dark shadows may cause accidents.
- 8. Personnel must be properly trained or well supervised when operating machinery.** Make sure you have clear and safe understanding of the machine you are operating.
- 9. Keep children and visitors away.** Make sure children and visitors are at a safe distance for you work area.
- 10. Keep your workshop childproof.** Use padlocks, Turn off master power switches and remove start switch keys.
- 11. Never leave machine unattended.** Turn power off and wait till machine has come to a complete stop before leaving the machine unattended.
- 12. Make a safe working environment.** Do not use machine in a damp, wet area, or where flammable or noxious fumes may exist.
- 13. Disconnect main power before service machine.** Make sure power switch is in the off position before re-connecting.
- 14. Use correct amperage extension cords.** Undersized extension cords overheat and lose power. Replace extension cords if they become damaged.
- 15. Keep machine well maintained.** Keep blades sharp and clean for best and safest performance. Follow instructions when lubricating and changing accessories.
- 16. Keep machine well guarded.** Make sure guards on machine are in place and are all working correctly.
- 17. Do not overreach.** Keep proper footing and balance at all times.
- 18. Secure workpiece.** Use clamps or a vice to hold the workpiece where practical. Keeping the workpiece secure will free up your hand to operate the machine and will protect hand from injury.
- 19. Check machine over before operating.** Check machine for damaged parts, loose bolts, Keys and wrenches left on machine and any other conditions that may effect the machines operation. Repair and replace damaged parts.
- 20. Use recommended accessories.** Refer to instruction manual or ask correct service officer when using accessories. The use of improper accessories may cause the risk of injury.
- 21. Do not force machinery.** Work at the speed and capacity at which the machine or accessory was designed.
- 22. Use correct lifting practice.** Always use the correct lifting methods when using machinery. Incorrect lifting methods can cause serious injury.
- 23. Lock mobile bases.** Make sure any mobile bases are locked before using machine.
- 24. Allergic reactions.** Certain metal shavings and cutting fluids may cause an allergic reaction in people and animals, especially when cutting as the fumes can be inhaled. Make sure you know what type of metal and cutting fluid you will be exposed to and how to avoid contamination.
- 25. Call for help.** If at any time you experience difficulties, stop the machine and call you nearest branch service department for help.

WARNING

Bobbin Sander Safety Instructions

Hare and Forbes Machinery House
requires you to read this entire Manual before using this machine.

- 1. Maintenance.** Make sure the Bobbin Sander is turned off and disconnect from the main power supply and make sure all moving parts have come to a complete stop before any inspection, adjustment or maintenance is carried out.
- 2. Bobbin Sander Condition.** Bobbin Sander must be maintained for a proper working condition. Never operate a Bobbin Sander that has damaged or worn parts. Scheduled routine maintenance should be performed on a scheduled basis.
- 3. Sanding Sleeve Condition.** Never operate a Bobbin Sander with a damaged or badly worn sanding sleeves. Replace if required.
- 4. Sander Rotation.** Be aware of the sander rotation when sanding.
- 5. Hand Hazard.** Keep hands and fingers clear from moving parts. Serious injury can occur if hand or finger tips come in contact with abrasives or moving parts.
- 6. Leaving a Bobbin Sander Unattended.** Always turn the Bobbin Sander off and make sure all moving parts have come to a complete stop before leaving the Bobbin Sander. Do not leave Bobbin Sander running unattended for any reason.
- 7. Avoiding Entanglement.** Remove loose clothing, belts, or jewelry items. Never wear gloves while machine is in operation. Tie up long hair and use the correct hair nets to avoid any entanglement with the Bobbin Sander moving parts.
- 8. Understand the machines controls.** Make sure you understand the use and operation of all controls.
- 9. Power outage.** In the event of a power failure during use of the machine, turn off all switches to avoid possible sudden start up once power is restored.
- 10. Work area hazards.** Keep the area around the Bobbin Sander clean from oil, tools, chips. Pay attention to other persons in the area and know what is going on around the area to ensure unintended accidents.
- 11. Workpiece Handling.** Never hold small workpieces with your fingers during sanding. Always support/feed the workpiece with push stick, table support, vice, or some sort of clamping fixture.
- 12. Hearing protection and hazards.** Always wear hearing protection as noise generated from Bobbin Sander and workpiece vibration can cause permanent hearing loss over time.
- 13. Dust hazards.** Always wear dust mask or respirator and eye protection when sanding. Use a dust collector as well to keep dust to a minimum.
- 14. Feeding material.** Always feed material into the direction of the sander sleeve. Never use excessive force when sanding or serious injury can occur.
- 15. Job Material.** Check material prior to sanding for nails, staple and other objects that make cause any danger when sanding.
- 16. Starting position/speed.** Never turn the Bobbin Sander on when the workpiece is resting on the sander sleeve. Allow sander to reach full speed before sanding.
- 17. Sanding.** Keep workpiece down toward the table whilst sanding. Workpiece may cause serious injury if not held correctly.
- 19. Stopping the Bobbin Sander.** Do not stop or slow the sander with your hand or workpiece. Allow the machine to stop on its own.
- 20. Wood dust may cause allergic reactions.** Make sure you know what type of dust you are exposed to as it may cause you an allergic reaction. Always wear an approved respirator.
- 21. Call for help.** If at any time you experience difficulties, stop the machine and call you nearest branch service department for help.

PLANT SAFETY PROGRAM

NEW MACHINERY HAZARD IDENTIFICATION, ASSESSMENT & CONTROL

Bobin Sander

Developed in Co-operation Between A.W.I.S.A and Australia Chamber of Manufactures
This program is based upon the Australian Worksafe Standard for Plant(NOHSC:1010-1994)

Item No.	Hazard Identification	Hazard Assessment	Risk Control Strategies <small>(Recommended for Purchase / Buyer / User)</small>
A	ENTANGLEMENT	HIGH	Eliminate, avoid loose clothing / Long hair etc.
C	CUTTING, STABBING, PUNCTURING	MEDIUM	Isolate power to machine prior to any checks or maintenance being carried out. Do not adjust or clean machine until the machine has fully stopped.
D	SHEARING	MEDIUM	Stand clear of moving parts on machine.
E	FRICITION	MEDIUM	Make sure all guards are secured shut when machine is on. Keep hands and body clear from bobbin sander spindle.
F	STRIKING	MEDIUM	Wear appropriate protective clothing. Wear safety glasses. Stand clear of moving parts on machine.
H	ELECTRICAL	MEDIUM	Remove all loose objects around moving parts. Ensure belts are in good condition and at correct tension. Always sand on the down stroke of the bobbin sander's rotation.
O	OTHER HAZARDS, NOISE, DUST.	LOW	All electrical enclosures should only be opened with a tool that is not to be kept with the machine. Wear hearing protection as required. Must be connected to a dust extraction.
Plant Safety Program to be read in conjunction with manufactures instructions			



www.machineryhouse.com.au



www.machineryhouse.co.nz

Authorised and signed by:
Safety officer:

Bobin Sander
.....
Manager:

Revised Date: Aug-08