



**sahinler**  
METAL MAKİNE ENDÜSTRİ A.Ş.

K-Q  
TSE-ISO-EN  
9000

# USER'S MANUAL

## MODEL AP 1020 – 1520 / 100 ton.

### UNIVERSAL HYDRAULIC PRESSBRAKES



**İzmir Yolu 22.km Mümin Gençođlu Cad. 16285 BURSA / TURKEY**

**Tel: +90-224-4700158 (6 lines plx)**

**Fax: +90-224-4700770**

**Web: [www.sahinlermetal.com](http://www.sahinlermetal.com)**

**Email: [info@sahinlermetal.com](mailto:info@sahinlermetal.com)**



**Şahinler**  
METAL MAKİNE ENDÜSTRİ A.Ş.



# CE DECLARATION

We as

**ŞAHİNLER METAL MAKİNE END. A.Ş.**  
İzmir Yolu 22.km  
Mümin Gençođlu Caddesi  
Bursa / TÜRKİYE

confirm that the machine

**AP 1020 – 1520 / 100 ton.**

Serial Number :  
Production Year :

complies with

**EC MACHINES DIRECTIVE 2006 / 42 / EU**  
**replaced with EC-Directives 91 / 368 / EWG and**  
**93 / 44 / EWG and**  
**93 / 68 / CEE**  
**EC-Low Voltage 73 / 23 / EWG**  
**EC - Noise Level Directives 86 / 188 / EWG**

and the machine also harmonized with the standards

**DIN EN 60204 Part 1**

Name : Mustafa PINARBAŞI  
Position : Production Director

BURSA, on.....

**LABELS**



**DANGER OF ELECTRIC**



**EMERGENCY STOP**



**GROUNDING SYSTEM**

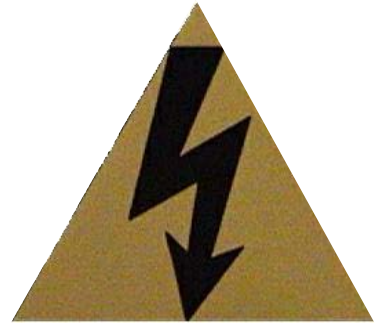

**WORKING VOLTAGE**



**DANGER**

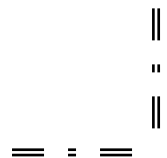

## **WARNING**

***Before operating machine;***

***You must follow these important steps***

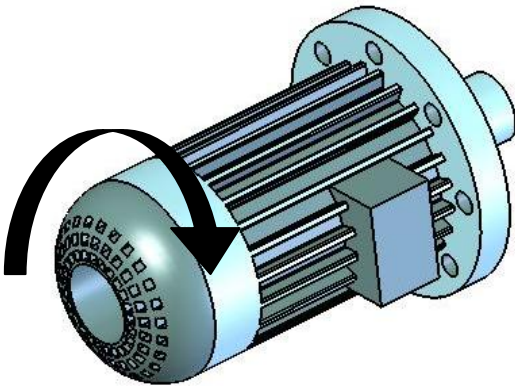
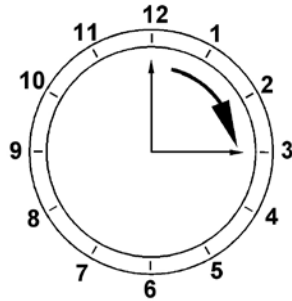

**RIGH**

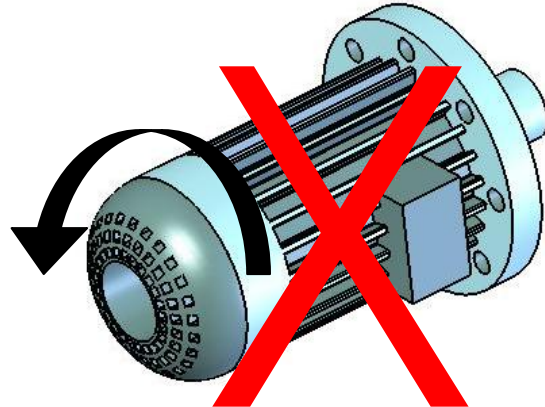

**WRONG**

- 1. Open the cover and check the direction of motor rotation***
- 2. If motor rotation direction is wrong, then change L1-L2 cables with themselves***

# **CONTENTS**

# **Page**

<i>General Notes</i>	1 – 2
<i>General Warranty Terms</i>	3
<i>Transport and Lifting</i>	4
<i>Technical Properties</i>	5
<i>Foundation Plan</i>	6
<i>Main dimensions</i>	7
<i>Area Requirement For the Machine and Tools</i>	8
<i>Setting up the machine</i>	9
<i>Safety Directives</i>	10 – 11
<i>Operation Instructions</i>	12
<i>Electric Box Overview</i>	13
<i>Correct working position</i>	14
<i>How to lift the table</i>	15
<i>Switch System</i>	16
<i>Maintenance and repair</i>	17 – 18
<i>Spare Part List and Drawing</i>	19 – 21

## GENERAL NOTES

### 1. Introduction

Thank you for choosing a Şahinler Sheet / Metal Working Machine. We are proud to have you in our long list of satisfied customers all over the world.

This User's Manual is absolutely for your safety and is essential for the machine to have a long production life. As long as you keep up with our Manual you will be able to run your machine smoothly and safely. Keep in mind that the machine is designed absolutely to perform maximum safety and for efficient working.

In this Manual you can find instructions and information about:

- Correct installations of the machine
- Description of the functional parts of the machine
- Set-up and start-up adjustments
- Correct standard and scheduled maintenance
- Simple safety regulations and accident prevention.

Therefore, as far as the user's safety is concerned, in this handbook the possible risks connected with machine operation are pointed out as follows:



**Attention:** Showing the risks of accident, if instructions are not followed.



**Warning:** Showing the probable damages to the machine or equipment, if the instructions are not strictly followed.



**Note:** It gives useful information.

It is certainly necessary that the operator should read and understand all the **Attention, Warning, Note** specified in this Manual before starting with operation of the machine and before any lubrication or maintenance intervention

On all steps of installation, operation and maintenance safety must be your first concern for the protection of yourself, other users and the service of the machine. In case of any failure please first refer to this Manual, and then if a solution cannot be found contact first of all the distributor where you purchased our product. Do not forget to refer to the drawings and the numbers for any spare part needed or to define any problem. Make sure you have the serial number and production year of the machine.

Our technical staff will make their best to help you in the most convenient way.

### 2. Transport

As soon as you receive the machine, check for any visible transport damages. Should there be any visible damages; report it straight away to the transporter company and of course Şahinler Metal Mak. End. A.Ş. or your supplier.

Remove any protective crates around the machine and read the instructions on related chapters of this Manual carefully to set up the machine. If the machine is damaged while transport, **immediately take some photographs for insurance claims.**

Take precautions while loading / unloading or moving the machine to avoid any injuries. Refer also to related chapter of this Manual for the best way of handling the machine.

### **3. Electrical Information**

All necessary connection procedure can be found on this Manual. Do not try to connect the machine before reading these procedures and fully understanding the drawings. For any unclear matters get in touch with Şahinler Metal Mak. End. A.Ş. or any of the Şahinler distributors. Have the machine connected by a qualified electric technician. For, as we made clear in the “general conditions of guarantee”, under no circumstances installing mistakes, including electrical connection mistake, can not be covered by guarantee agreement. Always turn off power before making any connections or disconnecting the machine.

### **4. Maintenance**

Your machine is designed and produced to work efficiently and smoothly. To achieve this you should also take care while operating the machine. Regard Maintenance sections to have the longest life from your machine. Try and use original spare parts where necessary and most importantly do not overload the machine or do not make any unauthorized modifications.

### **5. Safety**

Take all precautions possible to avoid any personal injury while using the machine. Keep in mind to protect the third party people around the machine. Refer to safety directives.

## GENERAL WARRANTY TERMS

- *Your machine is covered by manufacturer's guarantee for a period of **12 months** from the date of purchase against manufacture defects. The warranty period does not exceed 18 months from the date of delivery from the manufacturer's factory.*
- *Warranty covers only manufacture defective parts and / or components that are reported as "defective" by a Sahinler Technician or the Agent Technician and must be reported to Sahinler in writing by fax or email.*
- *The manufacturer is responsible for the supply of free of charge spares only and cannot be held responsible for loss of work.*
- *Shipping and customs fees for the spare part must be paid by the end-user.*
- *If a technician travel is necessary Sahinler will not charge for labor and workmanship costs but the customer must pay traveling and accommodation charges.*
- *A Warranty claim does not relieve the Customer from payment obligations.*
- *The Customer can not ask or demand any reimbursement of damage nor the Customer will have the right to extend or delay payment obligations nor the cancellation of order and the refunding of damages as the guarantee is given for the defective parts of the machine and not for the job.*



**Note:** *All warranty claims must be applied with the Model, Serial Number and the Manufacture Year of the machine.*



## TRANSPORT AND LIFTING OF THE MACHINE

The machine weight is approximately 3000 - 3300 kg. Use necessary cranes and lift as shown. Please take extra care during lifting and moving. Use a steel rope with hooks capable of carrying 5 ton. If necessary consult with specialized companies for lifting.

### Approximate Weight:

AP 1020 / 100 ton 1900 kg.

AP 1520 / 100 ton 2500 kg.

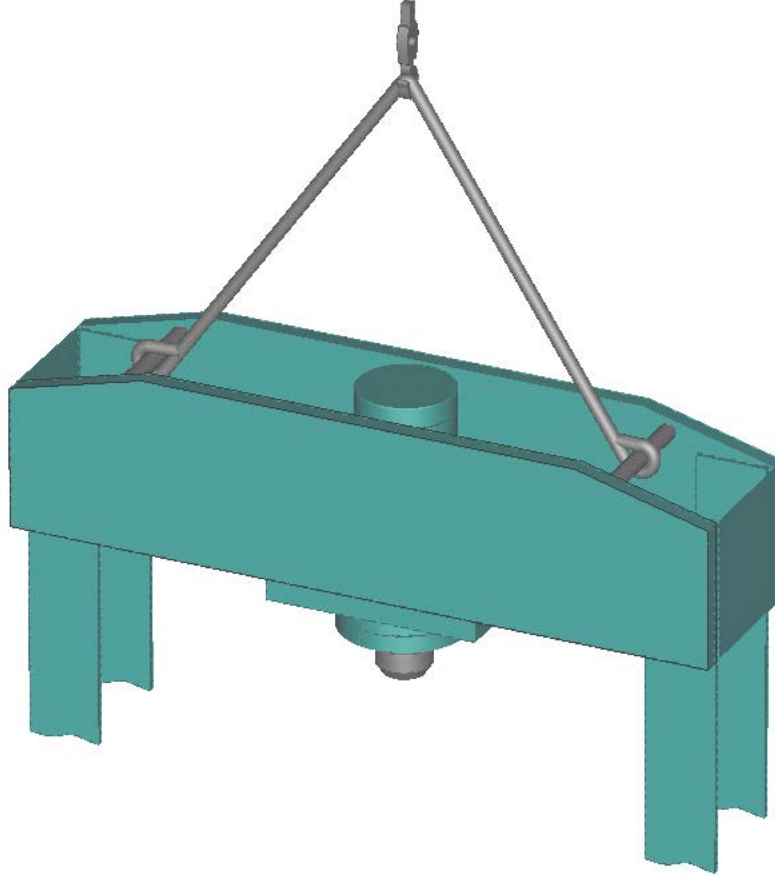

**Attention:** At the moment of receiving the machine, detach the protection nylons and verify the machine in order to determine any eventual transport damages that has occurred. Should you find out any damage occurred, indicate this case absolutely on the transport receipt certificate.

## OPENING THE PACKAGE

If any visible damage exist on the machine when you receive the machine immediately informs the dealer or manufacturer. Also never forget to state the visible damage on transport documents.

The packing material is completely safe and do not consist any environmentally dangerous articles. However they must be kept out reach of children as some nylon products in packing may cause suffocation if used as a toy etc.

## TECHNICAL PROPERTIES

<b>Universal Hydraulic Pressbrakes</b>			
<b>Model</b>		<b>AP 1020 / 100 ton</b>	<b>AP 1520 / 100 ton</b>
Press Power	kN	1000	1000
Max. pressure	bar	263	263
Stroke	mm	300	300
With of Working Area	mm	1020	1520
Distance Between Tables	mm	325	325
Bending Capacity	mm	8	8
Advance Speed	mm/sec	8	8
Working Speed	mm/sec	5	5
Return Speed	mm/sec	10	10
Motor Power	kW	7,5	7,5
Dimension of Die Table	mm	500x1020	500x1520
Die Table Center Hole	Ømm	100	100
Dimensions L x W x H	mm	2150x1000x2250	2650x1000x2250
Weight	kg	1900	2500

### STANDARD SPECIFICATIONS

- *Pressure gradeless adjustment (Pressure adjustment)*
- *Stroke gradeless Adjustment System (Stroke adjustment)*
- *Adequate work apace for large sheet metal*
- *Manual and two hand working*
- *Top Gooseneck pressbrake die*
- *Bottom die with 5 face prism*
- *Rexroth, Bosch or Parker hydraulic systems*
- *Electric's are Telemecanique or Siemens*
- *Arrangement system for taking down or up the table*
- *Suitable for CE regulations*
- *User manual book*

### Special Features

- *Optional Panbrake Die*
- *Down mound with different angles*
- *Down table special T – slots*
- *Working with foot pedal \**
- *Special order of fast working system \**

**Foundation Plan:**

On attached pages you can find foundation plan of the machine. You can bolt the machine if necessary.

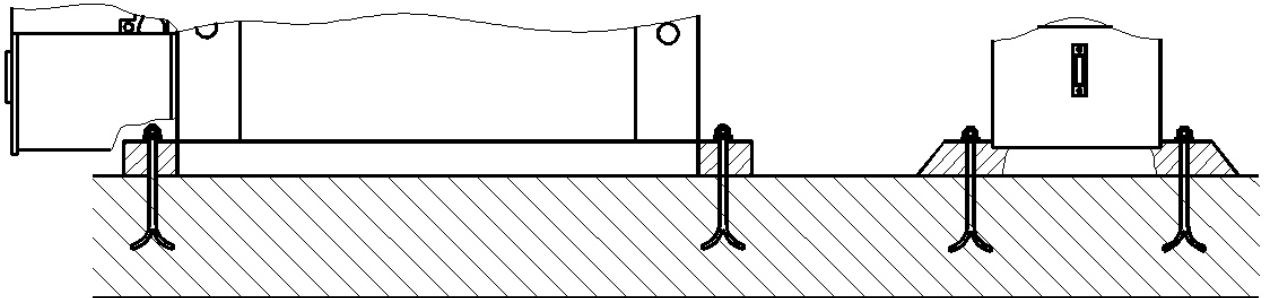
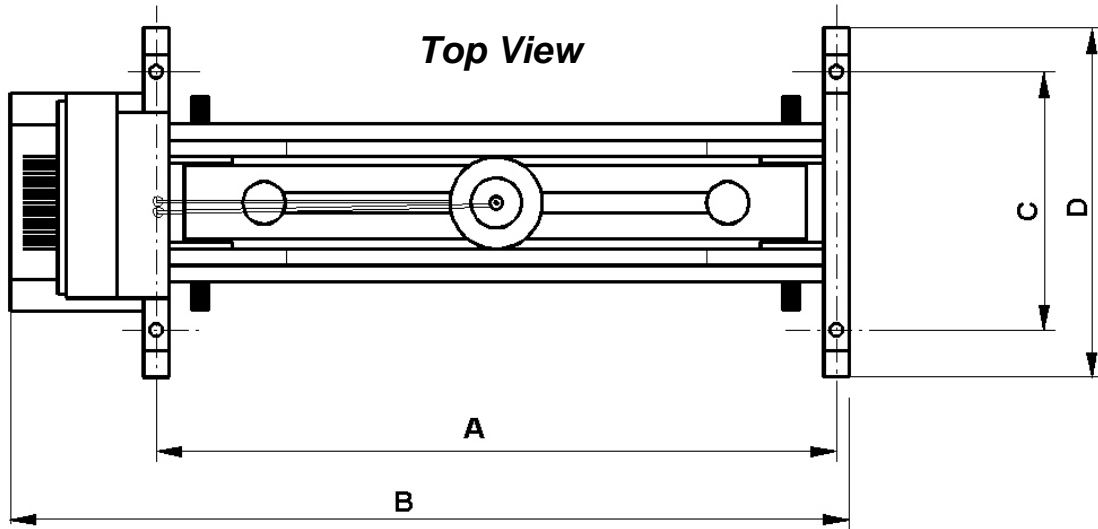

<b>MODEL</b>	<b>A</b>	<b>B</b>	<b>C</b>	<b>D</b>
<b>AP 1020 / 100 t</b>	1550	2150	665	1000
<b>AP 1520 / 100 t</b>	2050	2650	665	1000

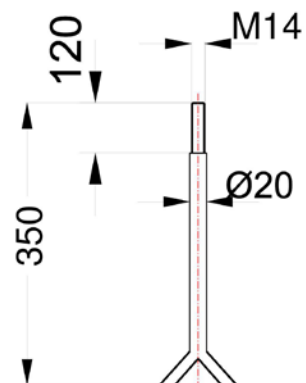

### Main Dimension of the Machine

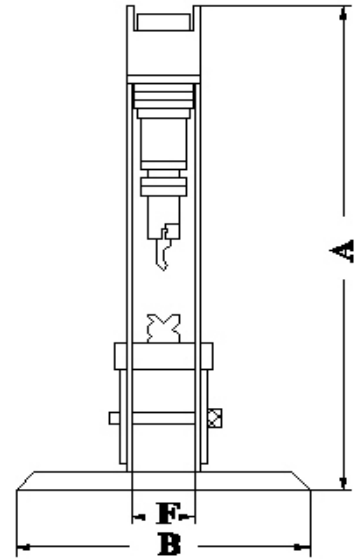
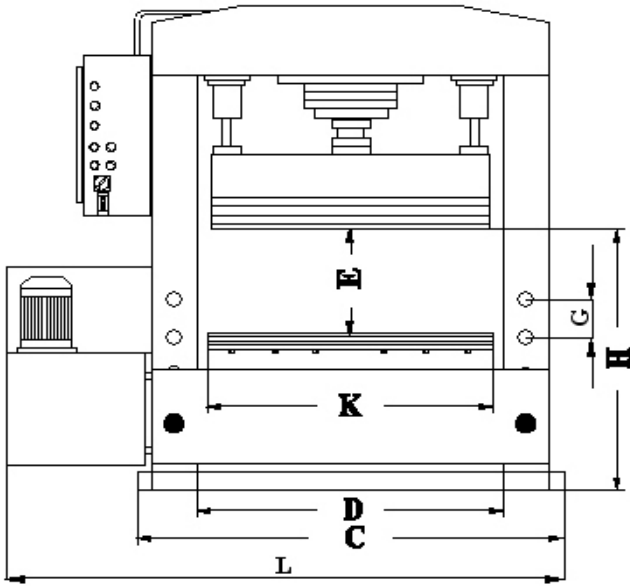

MODEL AP	A	B	C	D	E	F	G	H	K	L
	mm	mm	mm	mm	mm	mm	mm	mm	mm	mm
1020-100	2280	1000	1530	1070	260	250	190	1000	1020	2110
1020-150	2450	1000	1530	1070	260	290	190	1070	1020	2110
1520-100	2280	1000	2030	1570	260	250	190	1000	1520	2610
1520-150	2450	1000	2030	1570	260	290	190	1070	1520	2610

**Area Requirement For the Machine and Tools:**

The maximum tooling dimension are in conformance with the working surface and the distance between supports of the press.

The working zone is located at command area before the machine. The material to be treaded is only loaded from front part of the machine.

**Attention:** during the functioning the machine or functioning of the piston by an operator, never load material on the machine

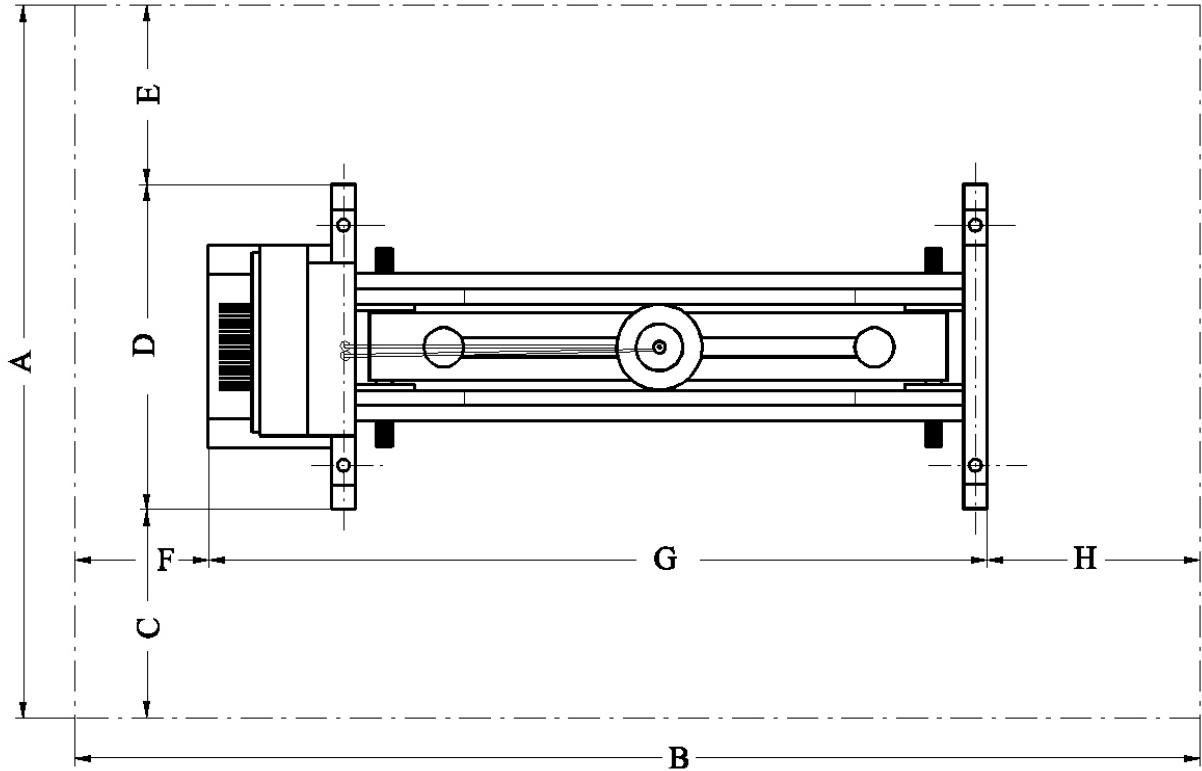

MODEL	A	B	C	D	E	F	G	H
AP 1020 / 100 t.	2600	3110	800	1000	800	600	2110	400
AP 1520 / 100 t.	2600	3610	800	1000	800	600	2610	400

## SETTING UP THE MACHINE

### 1. Lifting :

Use the crane to lift the machine. Be very cautious during lifting not to damage the machine or the personnel. Here are the weights of the machine:

Approximate weights:

AP 1020 / 100 ton.	3000kg.
AP 1520 / 100 ton.	3300kg.

### 2. Setting up the machine

For an efficient work and a long lasting machine beware these:

- Do not place the machine near a lathe or similar particle throwing machines
  - Do not place the machine near base shaking heavy machines such as power hammers
  - Cement the base of the machine
  - The base must be perfectly flat for efficient work
3. Clean off all protective lubricants on the machine before working
  4. Connect the electrics to a technician. If the machine is not specially designed it works on 380 V 50 Hz electricity. Be careful on R, S, T and C1, C2, C3 connections and of course the rotation of the motor. There is a rotation arrow on the motor, please check with it.
  5. Some parts arrive tied up to the machine to avoid transport loss and damage. Please remove them before working.
  6. The noise level on this machine is 70 decibels and complies with CSG Machine Noise Information Bureau 3<sup>rd</sup> Paragraph dated 18.01.1991
  7. The machine produces no excess heat, radiation, poisonous gases in all forms and harmful emissions described by CE – Rules.
  8. Manufacturer will not be responsible for any damages occurred during transport or any damages caused by electrical connection.

### Capacity Chart

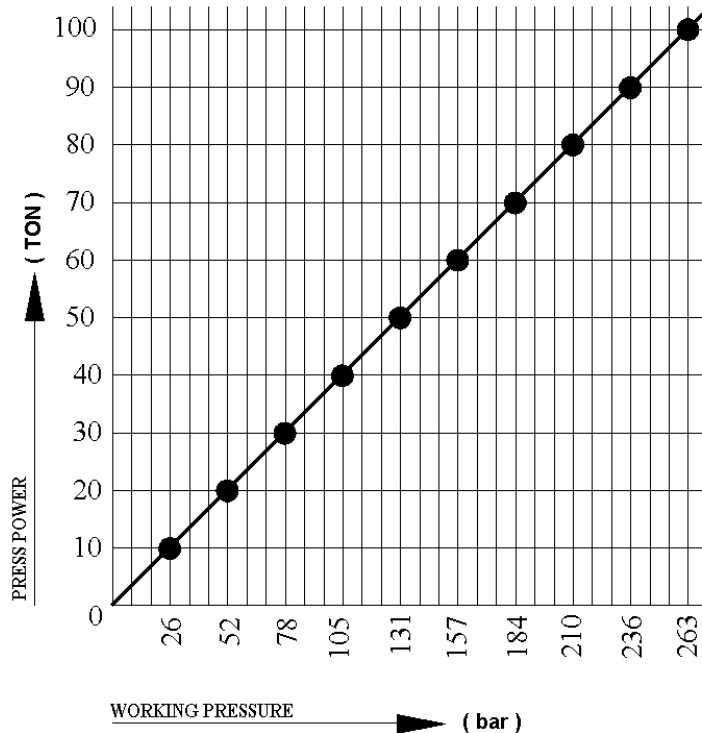

## **SAFETY DIRECTIVES**

### **EXPLANATION FOR OPERATOR**

*Operator under age of 16 years to operate the machine is strictly forbidden (EC-Directive). The operator of the machine should carefully read this manual and understand the danger he might be in if he misuses or abuses the machine. If any part of this manual is unreadable or illegible please contact to the dealer and manufacturer.*

*The owner of the machine should be responsible for operating the machine with qualified personnel.*

### **PERSONAL PROTECTION**

*Gloves and safety glasses and safety cap are recommended during operator.*



#### **Attention:**

- *No material should be fed if the machine is running.*
- *All emergency stop must be easily accessible.*
- *The user must be careful for third persons entering the operation area of the machine.*

### **General Safety Instructions**

*Following instructions are meant for the operator of the machine and it is the End-User's responsibility to make sure the operator reads and understands the following and the User's Manual for safe operation.*

- *Read the User's manual before operating the machine.*
- *Always inform electric faults to electric technicians.*
- *Keep your working dress or long hair or necklace etc away from rotating parts.*
- *Make sure you know the position of Emergency Stop Buttons on the machine.*
- *Switch off the machine when **NOT** working.*
- *Work with necessary safety clothes if necessary (safety shoes, glasses , earplugs etc).*
- *Control the Safety features before working and ensure they are working properly.*
- *See and understand Safety Labels on the machine.*
- *Perform periodic maintenance.*
- ***DO NOT** overload the machine.*
- *If you see abnormal behavior of the machine, stop the machine and inform your supervisor immediately.*
- *Be careful of other people around the machine during operation.*
- *Never modify electric unit.*
- *Never remove any mechanic or electronic safety features from the machine.*
- *Be extremely careful during transport or re-placement of the machine and follow transport instructions in the manual to safety handle the machine.*



**Attention:** Before the first use of the machine always check this list carefully for a safe start.

1. Check the emergency stop button on the command panel
2. Check for visible oil leak
3. Control of the buttons on the command panel

### **IMPORTANT POINTS**

- The machine must be used by qualified and technical personnel at all times.
- All modifications and changes on the machine without the written confirmation of manufacturer is forbidden and if such a case occurs all responsibilities of the manufacturer will be out of consideration.
- Any such modification is also breach of CE directives
- The machine can be stored and used in closed areas however beware not to put it near any explosive, flammable or in any dangerous articles.
- In case any use of non-original spares or accessories and in case of injuries then, the manufacturer will not responsible of such claims.
- Beware of third persons entering the operation area of the machine.
- Beware of any obstacles entering the operation area of the machine.
- In long term stand-by's turn the main button to position 0 (zero)

### **Electrical Connections**

#### **Danger**

All electric connections must be carried out by a qualified electric technician and any electrical fault must be immediately reported to a qualified electric technician.

This rating is for standard machine and can vary from country to country so please check the machine ID Plate found on the machine to see exact rating for specific countries.

### **Controlling the Direction of Rotation of Motors**

When you first start the machine you must control the Direction of Rotation of Motors.

There is an arrow pointing the running direction of the motor on the motor housing. If this is not clearly visible then test if the machine operates normally that is the Ram moves up and down normally. Try it for 10 seconds approximately and if you don't see any movement that means Direction of Rotation of Motor is not correct and the pump is not working so immediately stop the machine disconnect the electric and reverse the phase cables and try again.

#### **Warning**

Don't work the machine with wrong Direction of Rotation for more that 1 minute as this will burn out the pump.



## **Operation Instructions**

*Before proceeding with this section make sure that the operate understands all safety instructions given up to here. If there is any part not understandable or not readable do NOT operate the machine.*

### **Operation preparation**

*The machine must be prepared, installed and maintained at all times with the Main Power Switch at OFF (0) position.*

*Especially if you are going to install a new die or tool then the machine must be powered off and the Ram must be fixed with a wooden material so that it will not fall. Also:*

- *Check all guards and position devices*
- *Install the tool*
- *Check the positions of the tool*
- *Check all limit switches*
- *Power On the machine*
- *Prepare the material*
- *Adjust the stroke of the Ram*

### **Electric Box Push Buttons**

*Electric Box drawing and the identification of the buttons are shown on the following pages*

### **Emergency Stop Buttons**

*There is an Emergency Stop Button on the Mobile Control Panel. When this button is pressed the machine shuts down immediately and the ram stops instantly. To restart the machine you need to release the Emergency Button first then push the start button again.*

### **Two Hand Controls**

*Two Hand Control Buttons must be pushed simultaneously (approach 0.2 sec interval) or you will not be able to operate the machine. These are intended as a safety feature so that operator will not be able to put his/her hands into the danger zone while operating the machine.*

## ELECTRIC BOX OVERVIEW

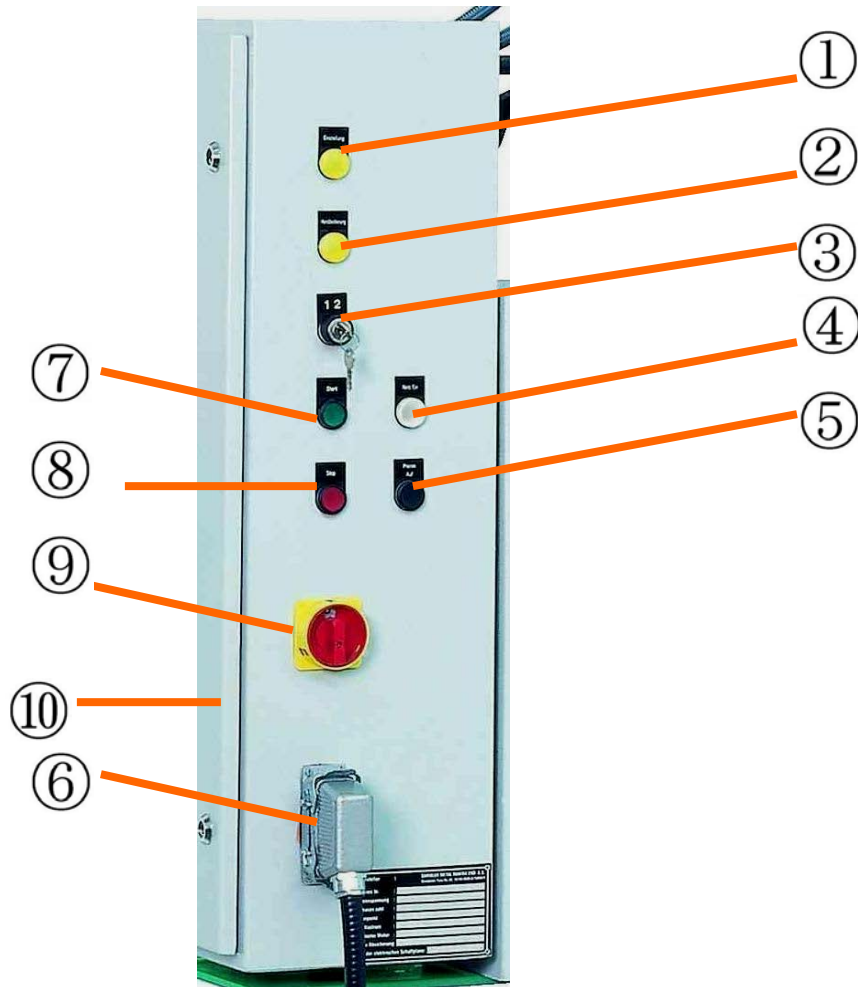

1. ADJUSTMENT
2. TWO HAND
3. SELECTIVE SWITCH
  - 1 – Adjustment
  - 2 – Two Hand Control
4. POWER ON INDICATOR
5. RAM UP
6. CONTROL PANEL PLUG – IN
7. START
8. STOP
9. MAIN POWER
10. BOX COVER
11. TWO HAND CONTROL BUTTONS
12. EMERGENCY STOP

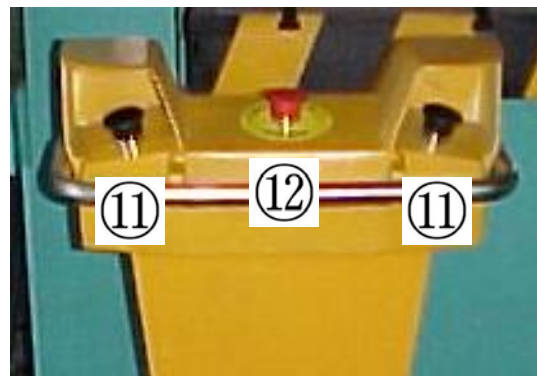

**PROTECTIVE DEVICES**

- 1. **Emergency STOP buton**
- 2. **Two Hand Control**



**Electric box**



**Switch system**

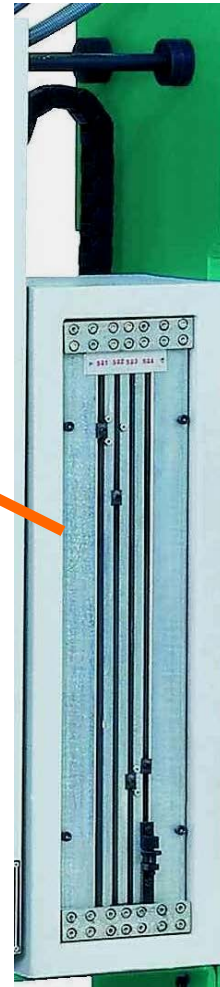

**CORRECT WORKING POSITIONS**

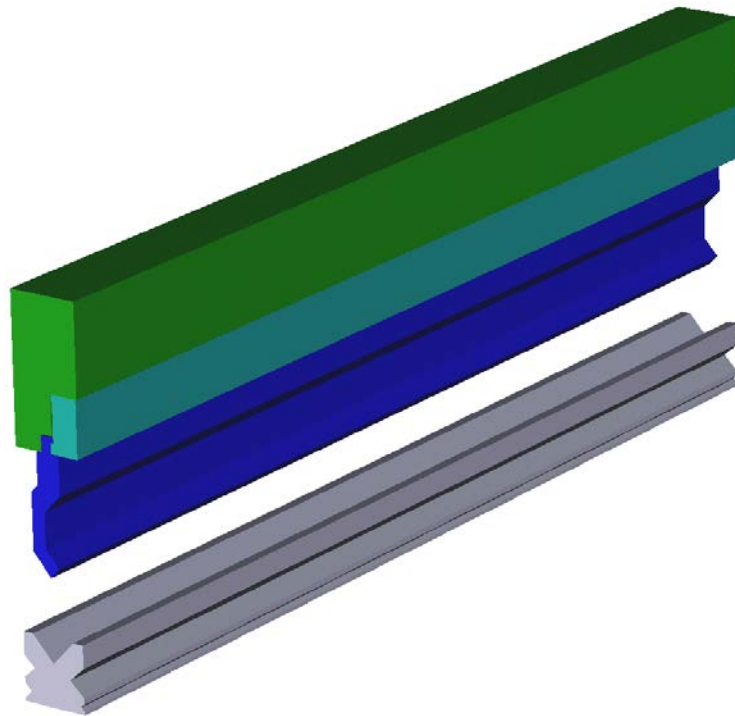
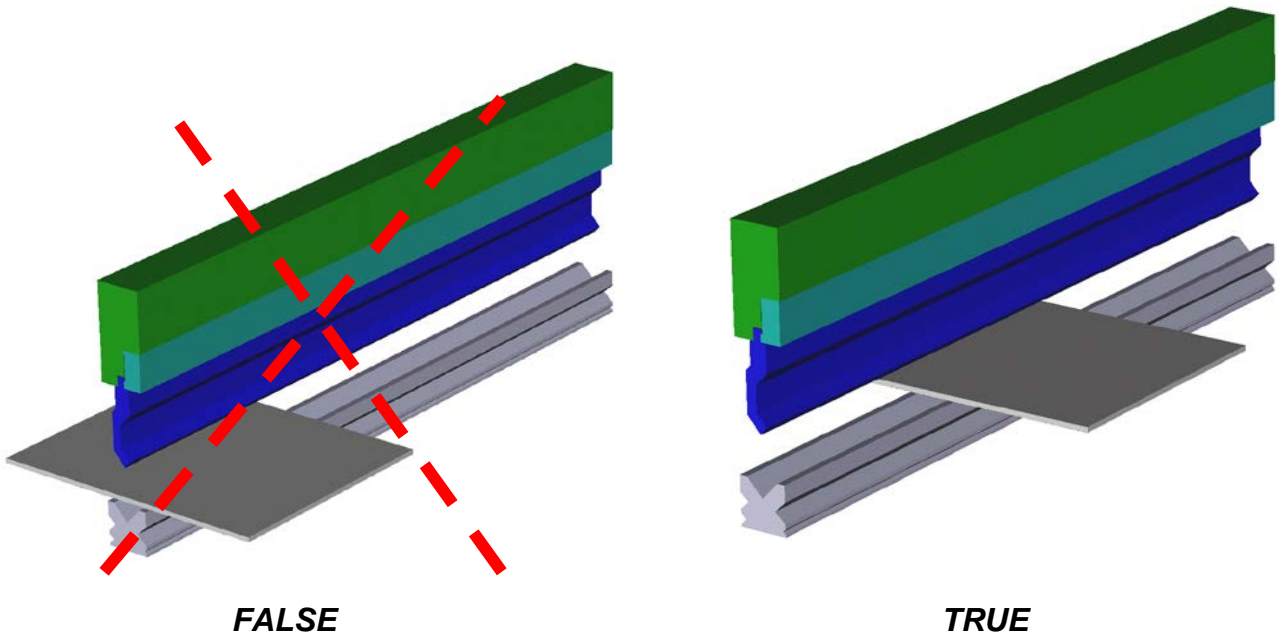

**CHECK PARALLELISM**



### **How to Lift the Table**

1. Lower the ram
2. Shut down the machine
3. Fix the table to the ram as shown
4. Remove fastening shafts on table holder
5. Adjust table by pushing the ram up down, very slowly
6. Fasten shafts to the table holder when adjustment is complete
7. Remove the lifting chain

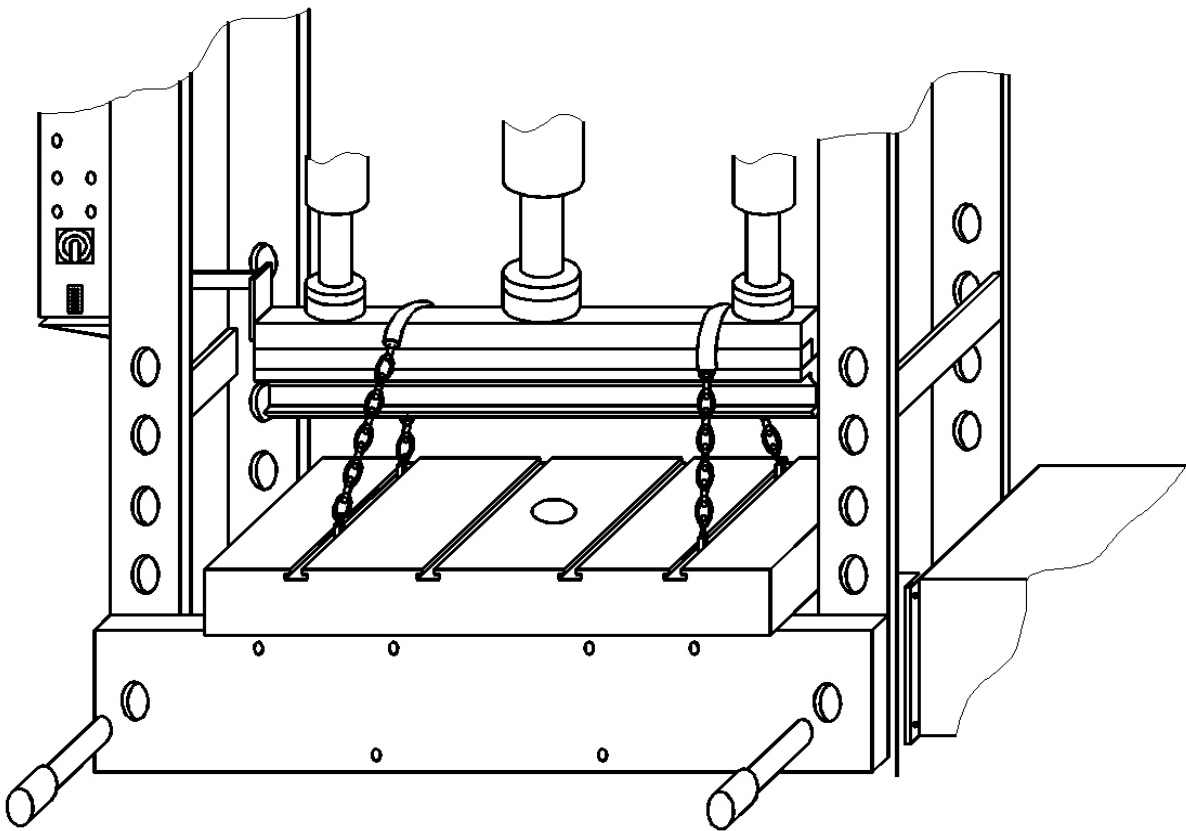

## SWITCH SYSTEM

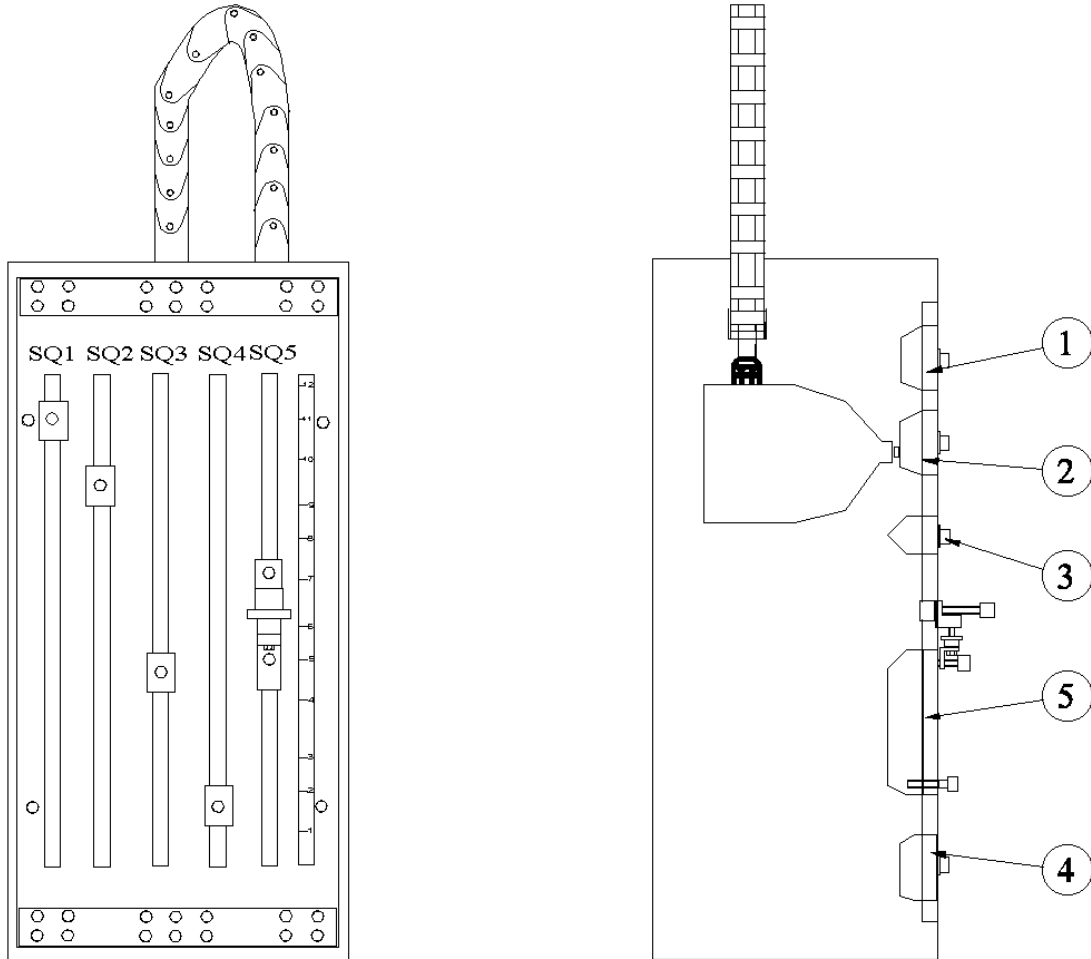

### Stroke Adjustment

**SQ1** Switch is the top safety Limit Switch. It is the last point the piston can move upward at all times. If for any reason the SQ2 does not stop the ram this switch stops the piston. This switch must **NOT** be changed at all times for safety.

**SQ2** Switch is the top limit switch for the ram. This switch is adjustable and is user to adjust the point where the operator wants the ram to stop on upward motion.

**SQ3** Switch is the speed switch which when activated slows the machine to working speed from Advance speed. This is adjustable also.

**SQ4** Switch is the bottom safety limit switch. It is the last point the piston can move downwards at all times. If for any reason the SQ5 does not stop the ram this switch stops the piston. This switch must **NOT** be changed at all times for safety.

**SQ5** Switch is the bottom limit switch for the ram. This switch is adjustable and is user to adjust the point where the operator wants the ram to stop on downwards motion.

## MAINTENANCE AND REPAIRS

### Maintenance Plan

<b>What</b>	<b>When</b>
Cleaning	Weekly
Hydraulic Oil Control and Filing	Weekly
Hydraulic Oil Change	Yearly
Hydraulic System Control	Yearly

### Warning:

- Do not move the piston when adjusting or setting tools
- Change and adjust tools only when the machine is turned off
- Prepare the table
- Set up and adjust the tooling
- Double – check everything before starting to work again

### Hydraulic System Maintenance

Hydraulic Oil can be harmful for the human skin. Avoid contact as much as possible. After finishing with maintenance clean your contact areas carefully.

**Protect the Environment:** recycle the used oil in the machine after removing it from the machine. Almost all material based oils are recyclable and are collected by Recycling Companies. Check with your local companies to recycle.

If there is any oil leak around the machine fill it with sand or sawdust to avoid any slippery surfaces which can be dangerous for other people. In general the Hydraulic System needs little maintenance and following points should be noted:

- Check the Oil level weekly from the Oil Gauge found on the hydraulic tank of the machine
- If the level is low fill with Shell Tellus Nr. 46 or equivalent.
- Once in 6 mounts control the Hydraulic filters inside the hydraulic tank and clean or replace if necessary
- Change the hydraulic oil at lease once a year. Fill with Shell Tellus Nr.46 or equivalent (ISO VG 46, DIN 51 519)
- Always close the tank cap tightly
- Control the bolts, seals, valves and Cylinder Seals for any visible damage once a week and replace them if necessary.

Oil Tank Capacity  
 AP 1020 / 100 t. 90 lt.  
 AP 1520 / 100 t. 90 lt.  
 Shell Tellus Nr. 46





NO:	MALZEMENİN ADI :	ADET:
1	HİDROLİK DEPO NG100 LT	1
2	DEPO KAPAGI VE HAVALIK SDK-045 HASSEL	1
3	YAĞ SEVİYE VE İSİ GÖSTERGESİ L=127 HASSEL	1
4	DISIJ POMPA 8,3 CC. SALAMI	1
5	ELEKTRİK MOTORU 7,5 KW 1450 D/D GAMAK	1
6	KAMPANA İK300 HASSEL	1
7	ELASTİK KAPLIN DC38 1P-38 HASSEL	1
8	BASINÇ EMN.VALFİ A04B2PZN PARKER	1
9	YON KONTROL VALFİ D1VW08CNJW PARKER	1
10	YON KONTROL VALFİ D1VW020ENJW PARKER	1
11	BASINÇ EMN.VALFİ RAH101SS0 PARKER	1
12	ÇEKVALF CVH103P PARKER	1
13	BASINÇ SALTERİ LP1A3 PINOMEK	1
14	MANO.Ø100x400 PANO TİP GLİS. PAKKENS	1
15	HİDROLİK BLOK STANDART HBB-1021	1
16		
17		
18		
19		
20		
21		
22		
23		
24		
25		
26		
27		
28		
29		
30		
31		
32		
33		
34		
35		
36		
37		
38		
39		
40		

PROJE :	SERDAR BAĞDAR
ÇİZEN :	İLBAYOĞLU
TARİH :	30.09.2017

FRMA :	<b>ŞAHİNLER A.Ş.</b>
MAKİNA/ SİSTEM ADI :	STANDART UNİTE (AT-AP) 100 TON

3 ADET  
G1\"  
MANSON

3 ADET  
G3/4\"  
MANSON

DEPO NG100 LT(OZEL)



## **MAIN PARTS Model AP**

1. *Frame*
2. *Oil Tank*
3. *Motor*
4. *Hydraulic Pipe*
5. *Hydraulic Pipe*
6. *Cylinder*
7. *Manometer*
8. *Switch*
9. *Electric Box*
10. *Adapter*
11. *Adapter Bolt*
12. *Adapter Bolt*
13. *Switch System*
14. *Adapter*
15. *Ram*
16. *Prism / Die*
17. *Lower Table*
18. *Side Supports / Table Holder*
19. *Side Supports Shaft*
20. *Side Supports Shaft*
21. *Bolt*
22. *Shaft Spring*
23. *Bolt*
24. *Nut*



MAIN PARTS Model AP

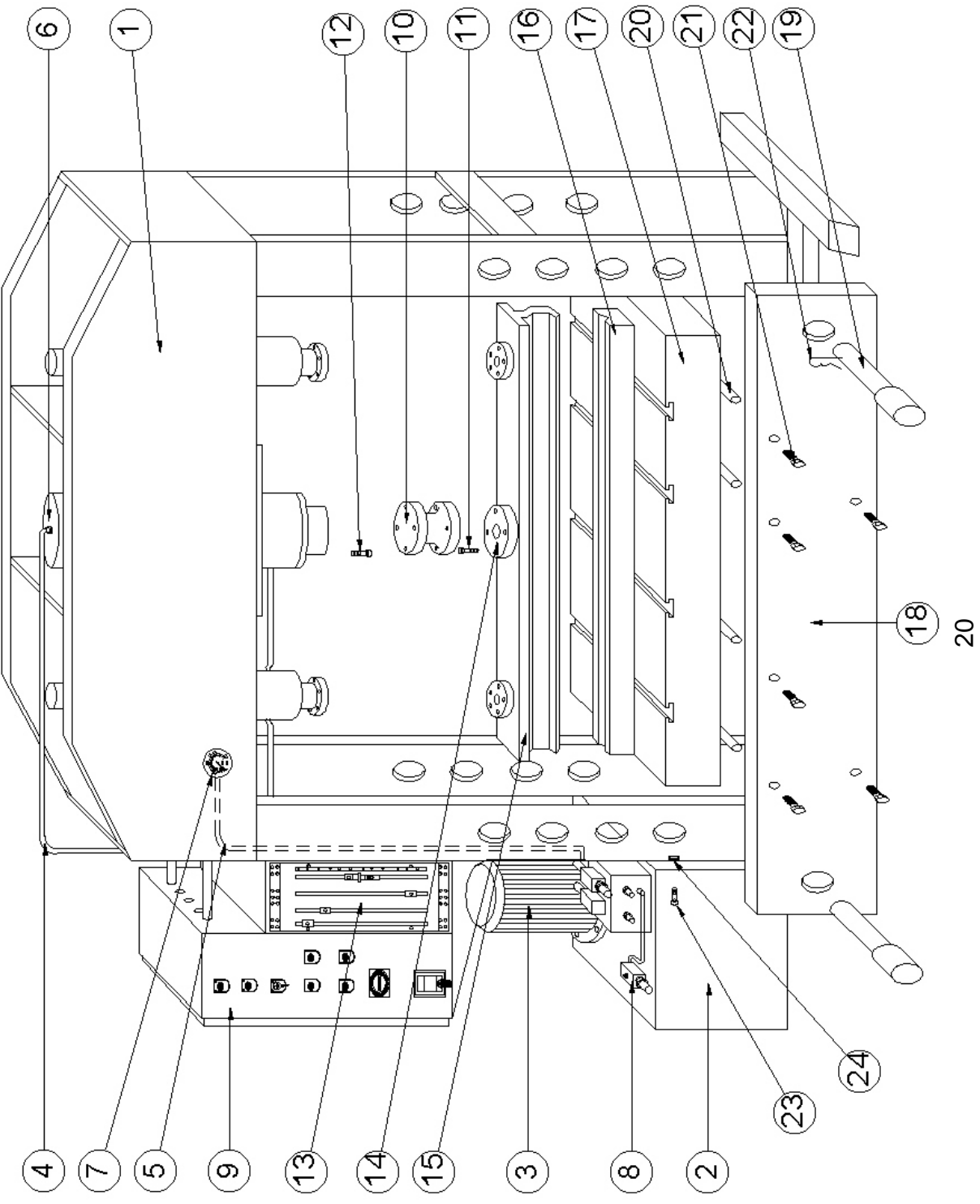



**AP – Back Guide ( OPTIONAL EQUIPMENT )**

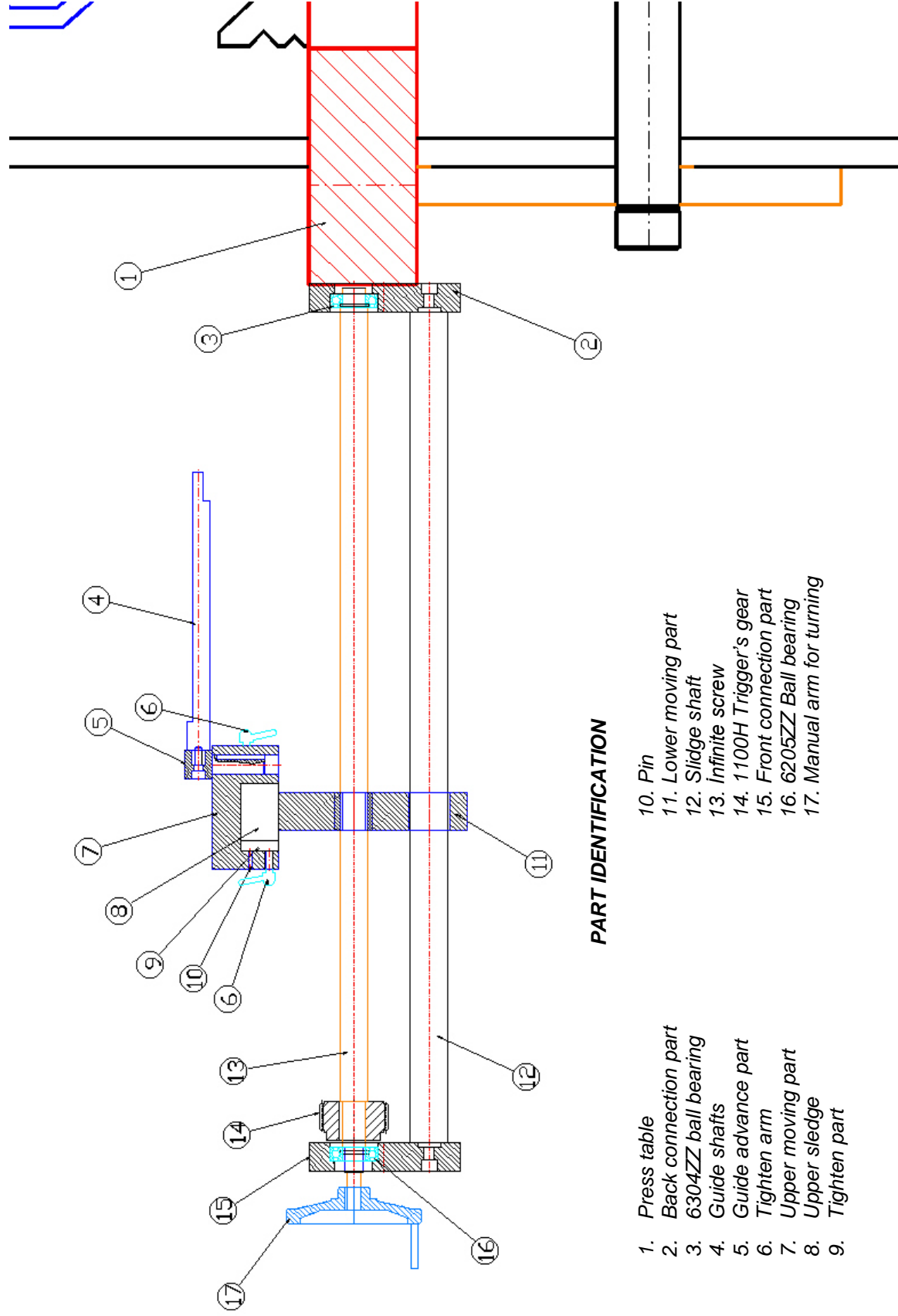

**PART IDENTIFICATION**

- |                         |                            |
|-------------------------|----------------------------|
| 1. Press table          | 10. Pin                    |
| 2. Back connection part | 11. Lower moving part      |
| 3. 6304ZZ ball bearing  | 12. Slidge shaft           |
| 4. Guide shafts         | 13. Infinite screw         |
| 5. Guide advance part   | 14. 1100H Trigger's gear   |
| 6. Tighten arm          | 15. Front connection part  |
| 7. Upper moving part    | 16. 6205ZZ Ball bearing    |
| 8. Upper sledge         | 17. Manual arm for turning |
| 9. Tighten part         |                            |



**gabini**  
METAL MACHINE INDUSTRIES A.S.



## AP – Back Guide (OPTIONAL EQUIPMENT)

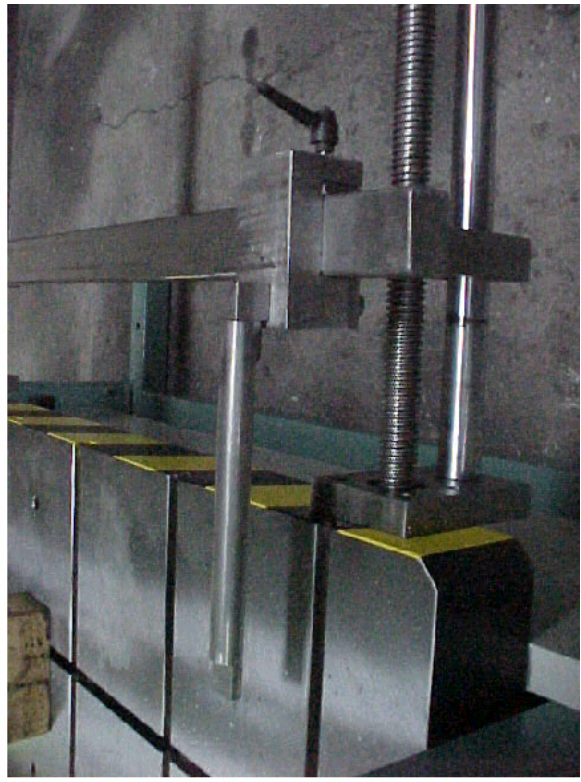
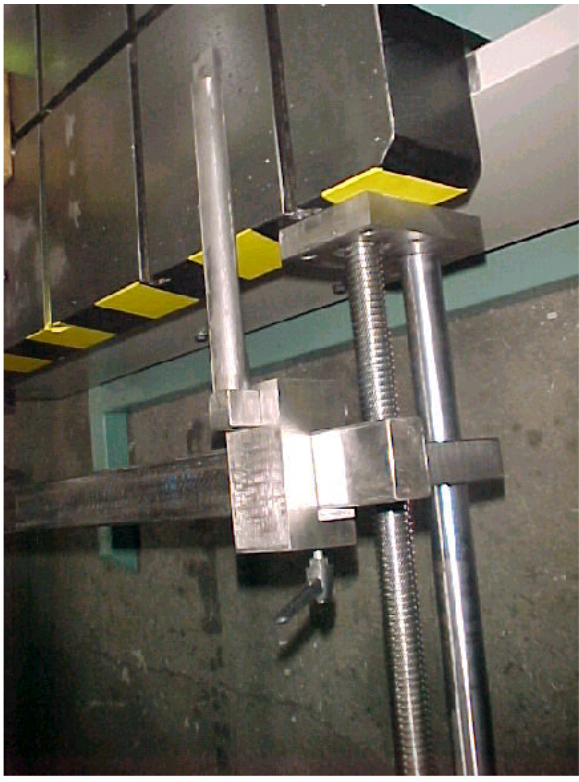

AP – 100 t. PART LIST FOR PISTON

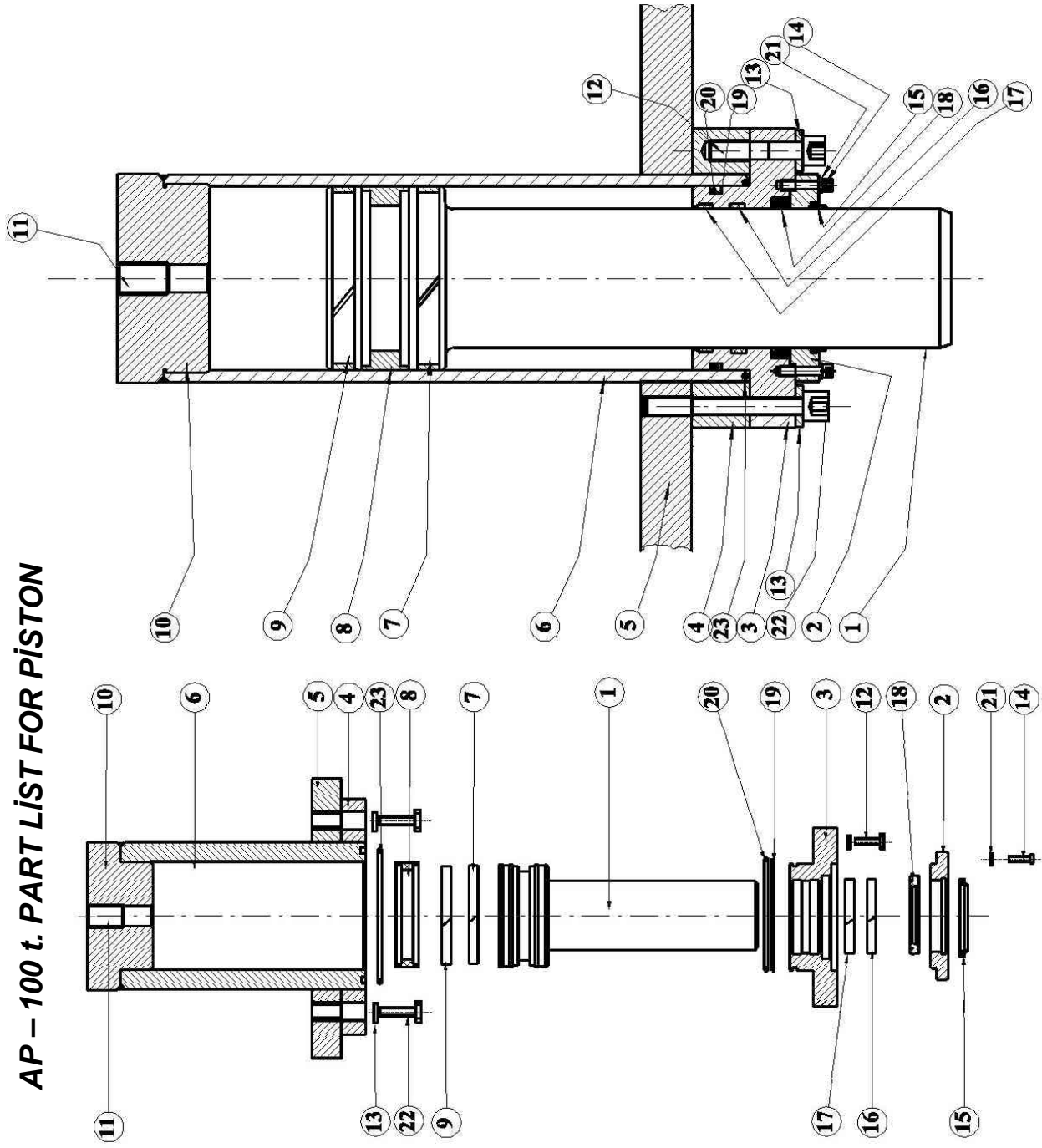

1. Piston
2. Cylinder Flange
3. Neck Flange
4. Neck of cylinder
5. Machine frame
6. Cylinder pipe
7. Rubber Band
8. Piston Seal
9. Rubber Band
10. Back Cylinder Cap
11. Hydraulic Oil – In
12. Assembly Bolt
13. Washer
14. Assembly Bolt
15. Scraper
16. Rubber Band
17. Rubber Band
18. Neck Seal
19. Support ring
20. O – Ring
21. Washer
22. Assembly Bolt
23. O – Ring



ŞAHİN MAKİNA SAN. VE TİC. LTD. ŞTİ.

## LFSS ŞAHİN MAKİNA SAN. VE TİC. LTD. ŞTİ.

İstiklal Mh. Fuat Kuşcuoğlu Cd. N:17  
Osmangazi Bursa TürkiyeTel.: 0090.224.245 91 07  
Faks: 0090.224.249 49 65

Müşteri :  
Tesis tanımı :  
Çizim numarası : 503  
Komisyon :

Üretici şirket : LFSS Şahin Makina  
Dosya ismi : AP HYDRAULIC PRESS (100 TON)  
Proje ismi :  
Marka :  
Tip :  
Kurulum :  
Proje yöneticisi :

Oluşturma tarihi : Sorumlu : BULENT SEVIK En yüksek sayfa : 11  
Durum : 02.08.2017 Sorumlu : BULENT SEVIK Toplam sayfa : 11

Tarih	İsim	Norm	Sub.f.	Sub.b.	Kapak sayfası	Yer	S.	Testis	11	S.
2017.08.02.09:17:35			503							
		BULENT SEVIK								
2017.08.02.09:17:35			Original			503				









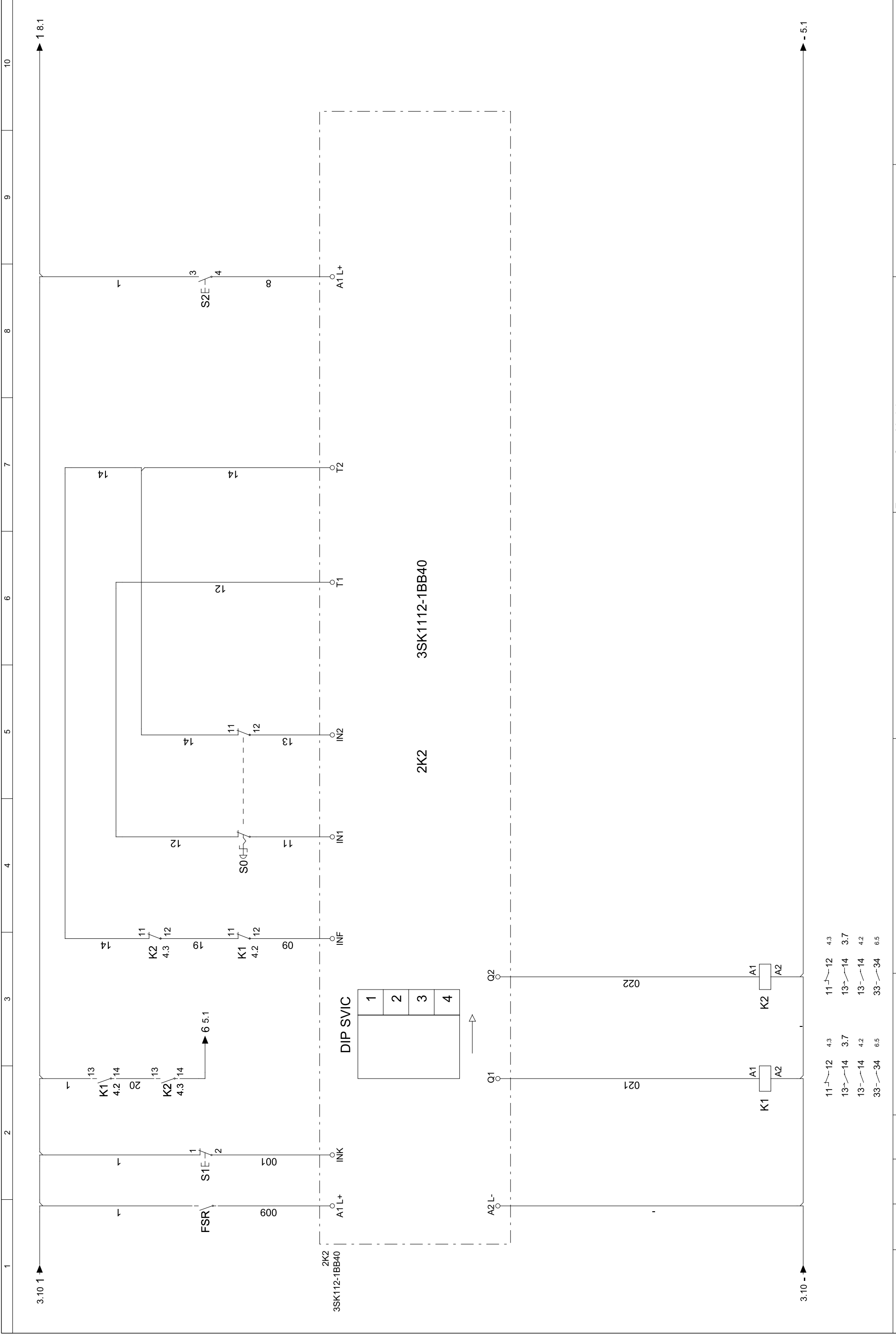

Emergency Stop Modul		503		Yer		Tesis		11 S.	
Değişiklikler		Tarih		İsim		Sub.f.		Sub.b.	
		2017.08.01, 13:56:15		BULENT SEVİK		Orjinal		503	
		2017.08.01, 13:56:15		Kontrol					
		Norm							

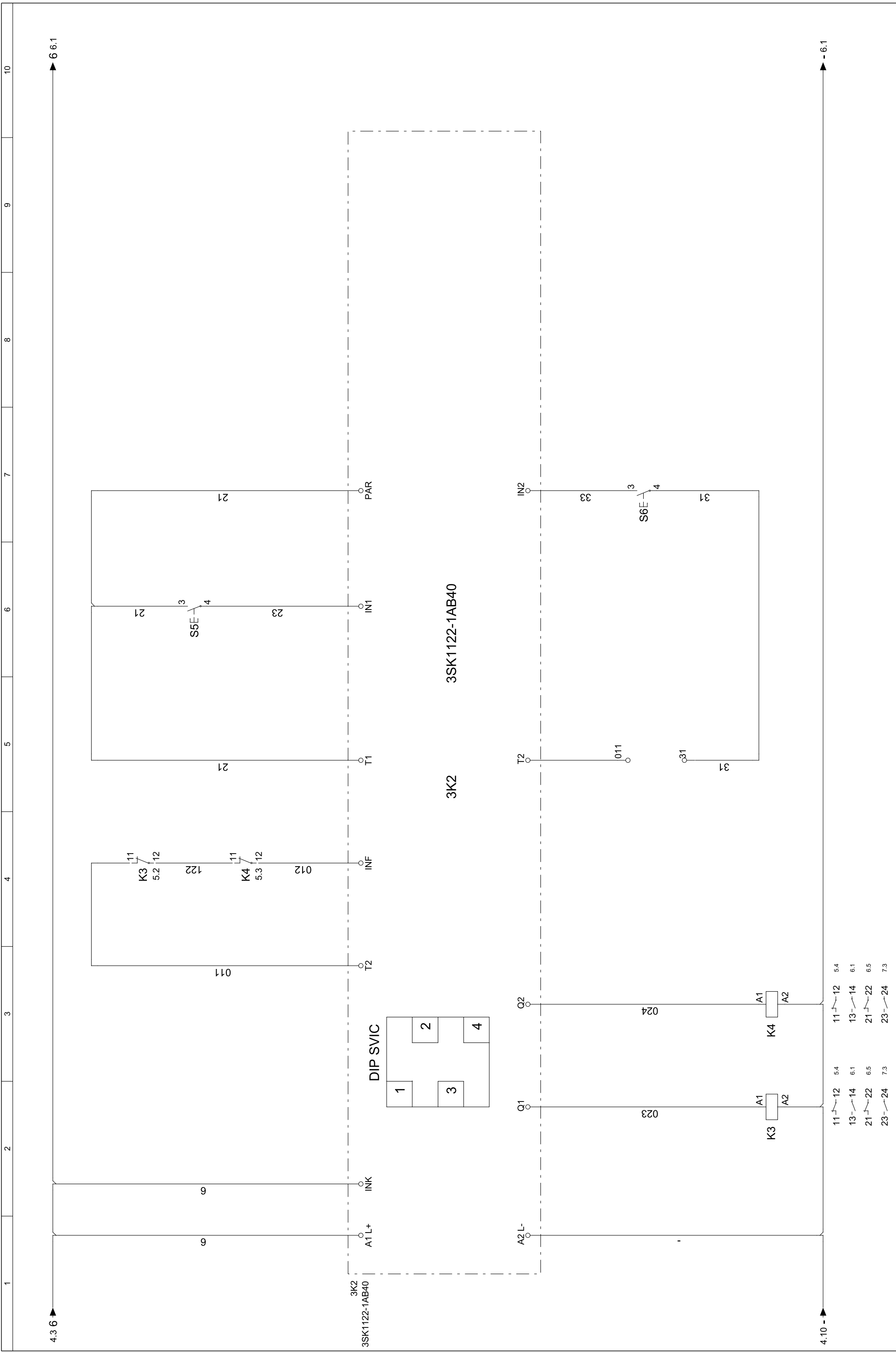

Two Hand Control Modul		503	Yer	Tesis	11	S.
Değişiklikler	Tarih	İsim	Sub.f.	Sub.b.		
	Tarih	2017.08.01, 13:59:49	503			
	Çizen	BULENT SEVIK				
	Kontrol	2017.08.01, 13:59:49				
	Norm	Orjinal				

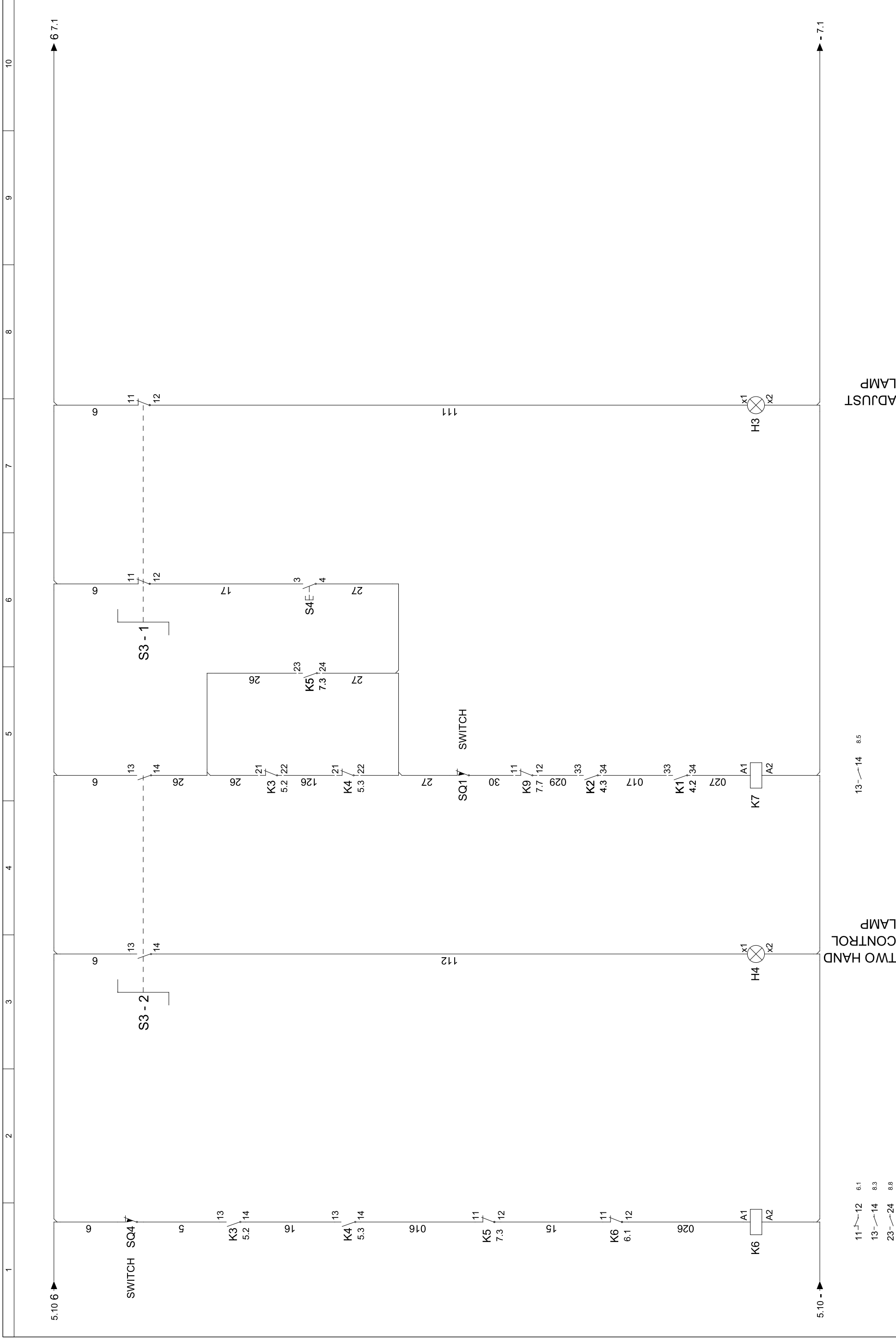

Değişiklikler	Tarih	İsim	Norm	503	Control Group - 1	503	Yer	Tesis	11 S.
	Tarih	İsim	Norm	503					
	2017.08.01, 14:00:29	BULENT SEVİK	Çizen						
	2017.08.01, 14:00:29		Kontrol						
			Norm						

- 11-12 6.1
- 13-14 8.3
- 23-24 8.8

5.10 - - 7.1

5.10 6 - - 7.1

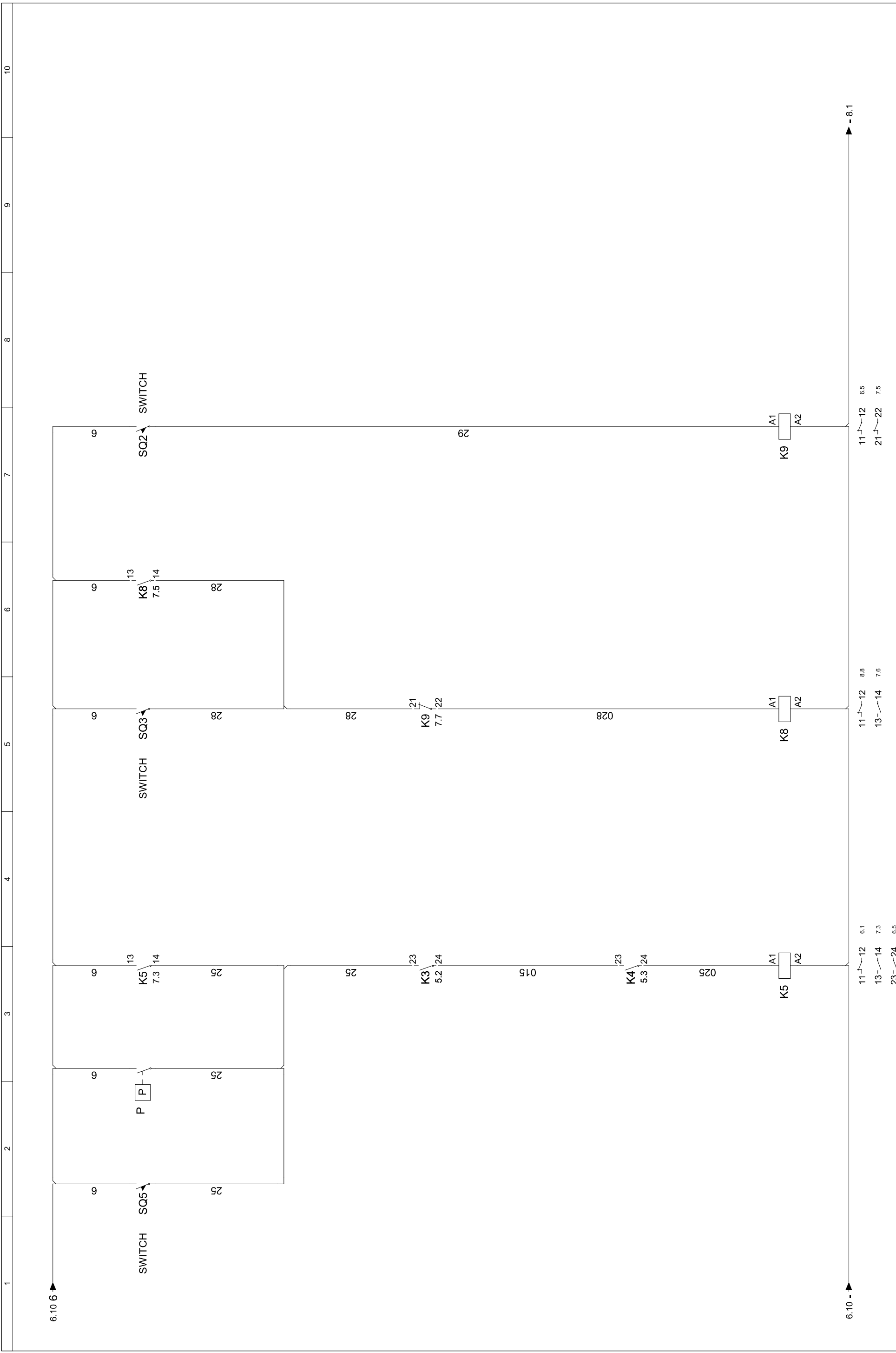

Değişiklikler		Tarih	İsim	Sub.f.	Sub.b.	Control Group - 2		503	Yer	Tesis	11 S.
		Tarih	2017.08.01, 14:01:31	503							
		Çizen	BULENT SEVİK								
		Kontrol	2017.08.01, 14:01:31								
		Norm		Orjinal							

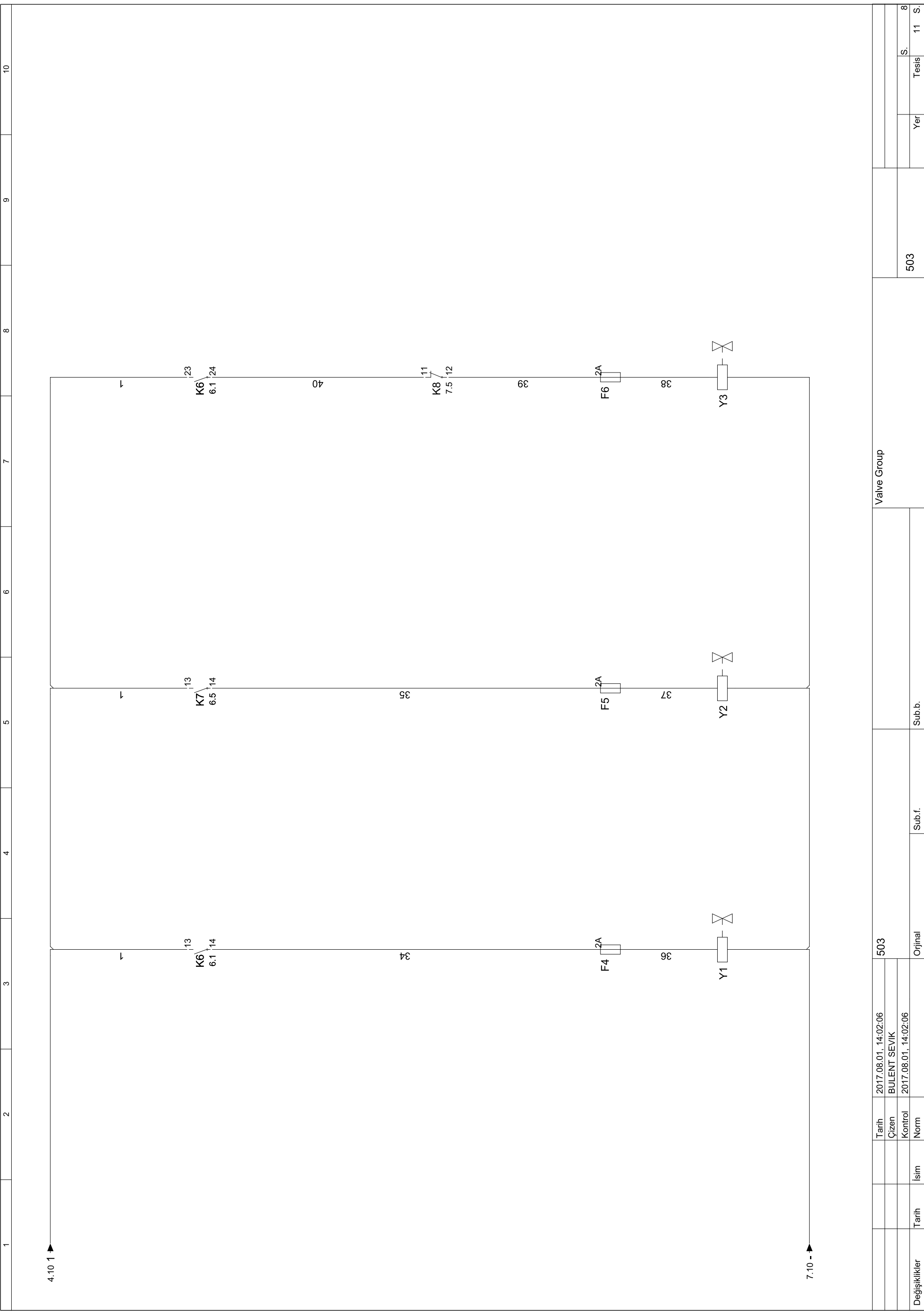

Valve Group

503

Tarih	İsim	Norm
2017.08.01, 14:02:06	BULENT SEVIK	Çizen
2017.08.01, 14:02:06		Kontrol
		Norm

Değişiklikler	Tarih	İsim	Norm

Sub.f.	Sub.b.
Orjinal	

Yer	Tesis	11 S.
	503	

**ELECTRIC BOX**

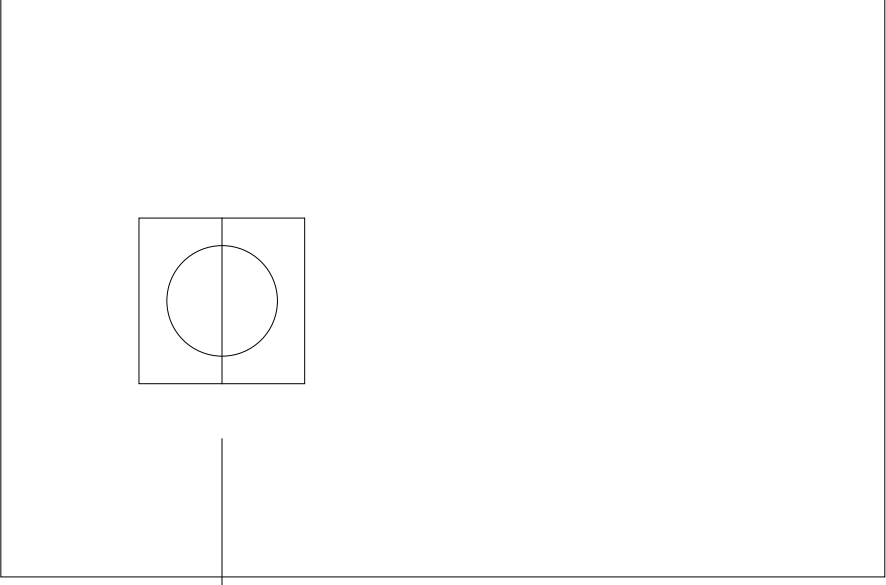

8

**ELECTRIC BOX**

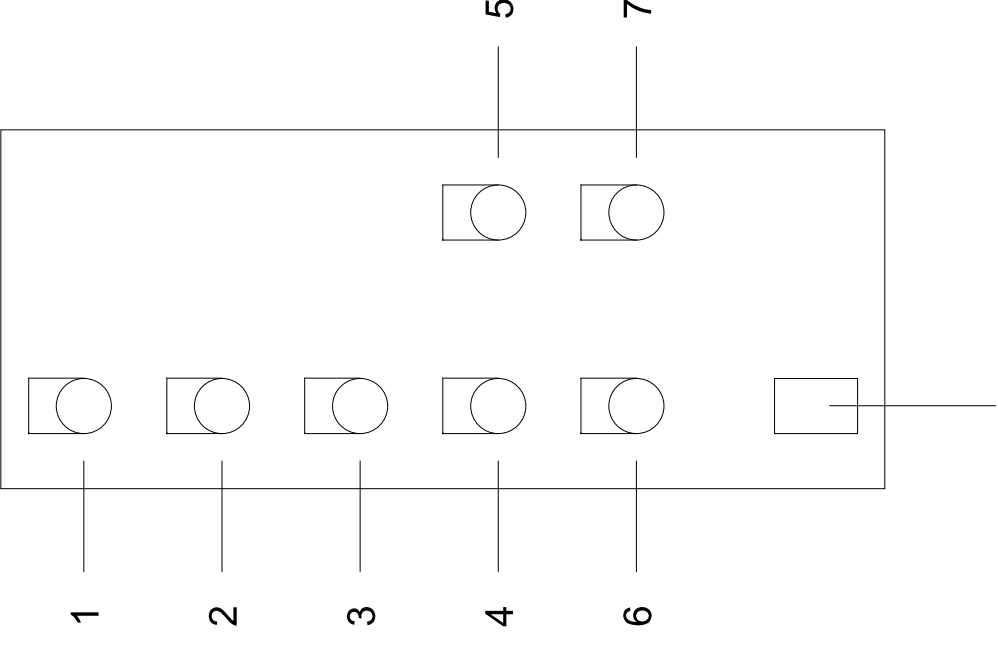

- 1 - ADJUSTMENT
- 2 - TWO HAND CONTROL
- 3 - SELECT SWITCH
  - 1 - ADJUSTMENT
  - 2 - TWO HAND CONTROL
- 4 - START BUTTON
- 5 - POWER ON
- 6 - STOP BUTTON
- 7 - RAM UP
- 8 - MAIN SWITCH
- 9 - EMERGENCY STOP
- 10 - TWO HAND BUTTONS

**CONTROL TABLE**

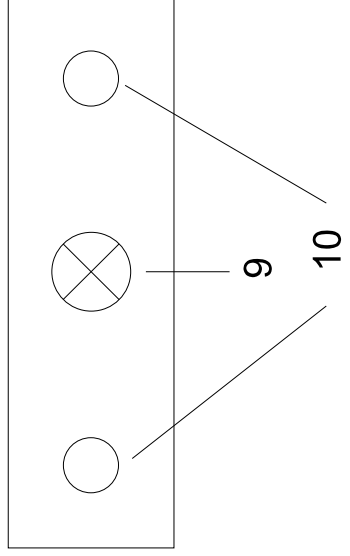

Tarih	2017.08.01, 14:03:52	503
Çizen	BULENT SEVİK	
Kontrol	2017.08.01, 14:03:52	
Norm		
Değişiklikler	İsim	Orjinal
	Sub.f.	Sub.b.

**Electrical Cabinet and Control Table**

503	
Yer	S.
Tesis	11 S.

ELECTRIC BOX INSIDE

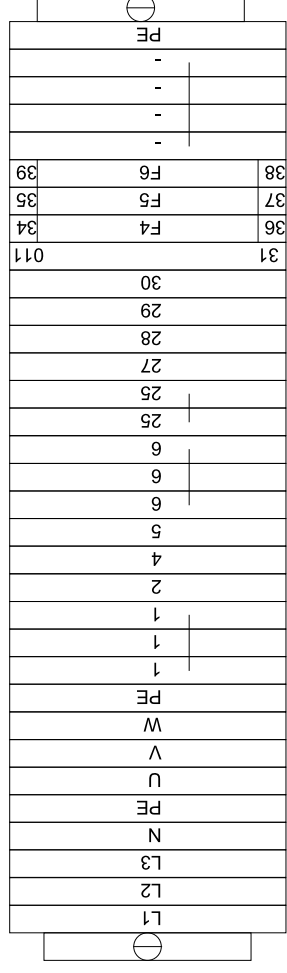
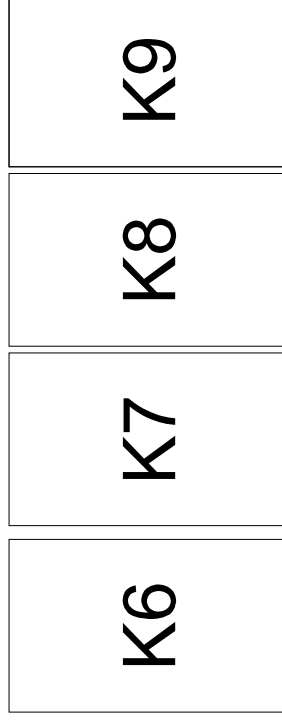
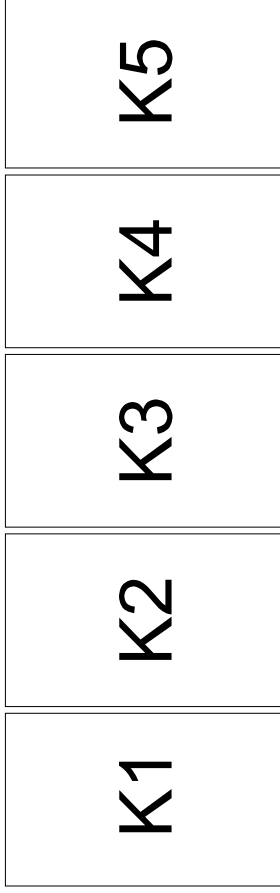
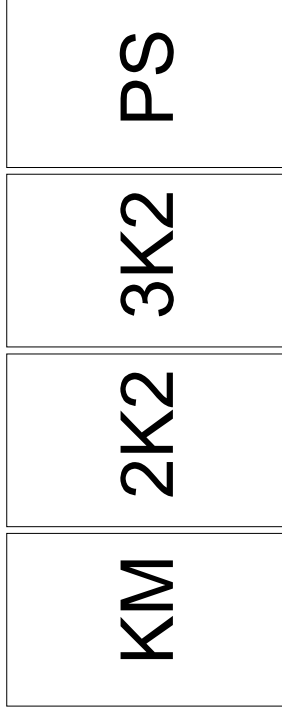
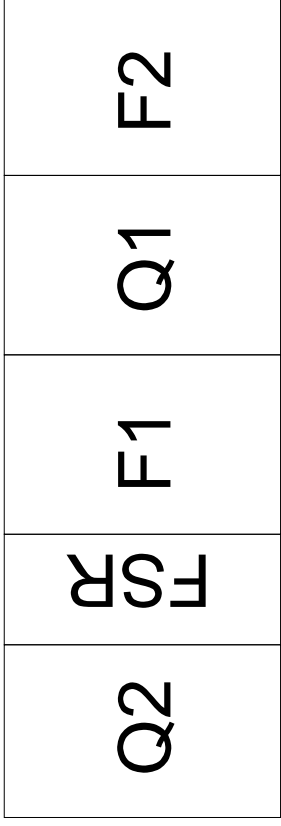

Electrical Cabinet Scheme		503	
Değişiklikler	Tarih	İsim	Norm
	2017.08.01, 14:04:35	BULENT SEVIK	2017.08.01, 14:04:35
	Çizen		
	Kontrol		
	Norm		
	Sub.f.	Sub.b.	
			503
		Yer	Tesis
			11 S.
			10 S.

## ELECTRICAL PART LIST

CODE	EXPLANATION	ORDER NUMBER	MANUFACTURER
Q1	MAIN SWITCH	3LD2013-0TK53	SIEMENS
Q2	MOTOR PROTECTION RELAY ( AUXILIARY CONTACT OREDER NUMBER---3RV2901-1E)	3RV2031-4BA10	SIEMENS
G1	POWER SUPPLY (INPUT 50/60Hz AC100-240V 3,1A OUTPUT DC24V 10A)	S8VK-C24024	OMRON
FSR	PHASE SEQUENCE RELAY	K88DS-PH11	OMRON
KM	PUMP MOTOR CONTACTOR ( UPPER BLOCK ----- ORDER NUMBER)	3RT2025-1BB40	SIEMENS
2K2	STOP MODULE	3SK1112-1BB40	SIEMENS
3K2	TWO HAND MODULE	3SK1122-1AB40	SIEMENS
K1 - K2	CONTROL CONTACTORS	3RH2131-1BB40	SIEMENS
K3-----K9	CONTROL CONTACTORS	3RH2122-1BB40	SIEMENS
F4-F5-F6	VALVE FUSES	ASK-2S 2A	KLEMSAN
H1	POWER ON LAMP	3SU1152-6AA60-1AA0	SIEMENS
S0	EMERGENCY STOP (BUTTON BODIES ORDER NUMBER ZB4B102+ZBE102)	ZB4 - BS 864	SCHNEIDER
S1 - H5	STOP BUTTON - OVERLOAD LAMP	3SU1152-0AB20-1CA10	SIEMENS
S2 - H2	START BUTTON-LAMP	3SU1152-0AB40-1BA0	SIEMENS
S3	SELECT SWITCH NORMALLY OPEN CONTACT ORDER NUMBER (3SU1400-1AA10-1BA0) (3SU1400-1AA10-1CA10)	3SU1150-4BF11-1BA0	SIEMENS
H3 - H4	ADJUSMENT AND WORKING LAMP	3SU1152-6AA30-1AA0	SIEMENS
S4	RAM UP ADJUSTMENT BUTTON	3SU1150-0AB10-1BA10	SIEMENS
S5 - S6	TWO HAND BUTTONS ( BUTTON BODIES ORDER NUMBER ZB4-BZ101)	ZB4-BR2	SCHNEIDER
SQ1----SQ5	ADJUSMENT AND SECURITY SWITCHES	BNS00KE	BALLUFF
	BUTTON BODIES	ZB4-B2402	SCHNEIDER
	NO CONTACTS	ZBE-101	SCHNEIDER
	MULTI POLES MACHINE PLUG - IN ( 16 POLES )	TEY16PS16	SCHNEIDER
	MULTI POLES MACHINE PLUG ( 16 POLES )	TEX16WP16	SCHNEIDER

Tarih	2017.08.01, 14:07:17	503	Electrical Part List	
Çizen	BULENT SEVİK			
Kontrol	2017.08.01, 14:07:17			
Norm				
Değişiklikler	İsim	Sub.f.	Sub.b.	503
				Yer
				S. 11
				Tesis
				11 S.



