

# SPARE PARTS SECTION

## HYDRAULIC PRESS

### Model. HP-30P

Order Code P145

*Edition No* : HP-30P-2

*Date of Issue* : 4/2020

The following section covers the spare parts diagrams and lists that were current at the time this manual was originally printed. Due to continuous improvements of the machine, changes may be made at any time without notification.

#### HOW TO ORDER SPARE PARTS

1. Have your machines **model number, serial number & date of manufacture** on hand, these can be found on the specification plate mounted on the machine
2. A scanned copy of your parts list/diagram with required spare part/s identified
3. Go to [www.machineryhouse.com.au/contactus](http://www.machineryhouse.com.au/contactus) and fill out the enquiry form attaching a copy of scanned parts list.

#### CONTENTS

Pump Spare Parts Diagram.....	21
Pump Spare Parts List.....	22
Ram Spare Parts Diagram.....	23
Ram Spare Parts List.....	24
Press Spare Parts Diagram.....	25
Press Spare Parts List.....	26

**HP-30P PUMP SPARE PARTS DIAGRAM**

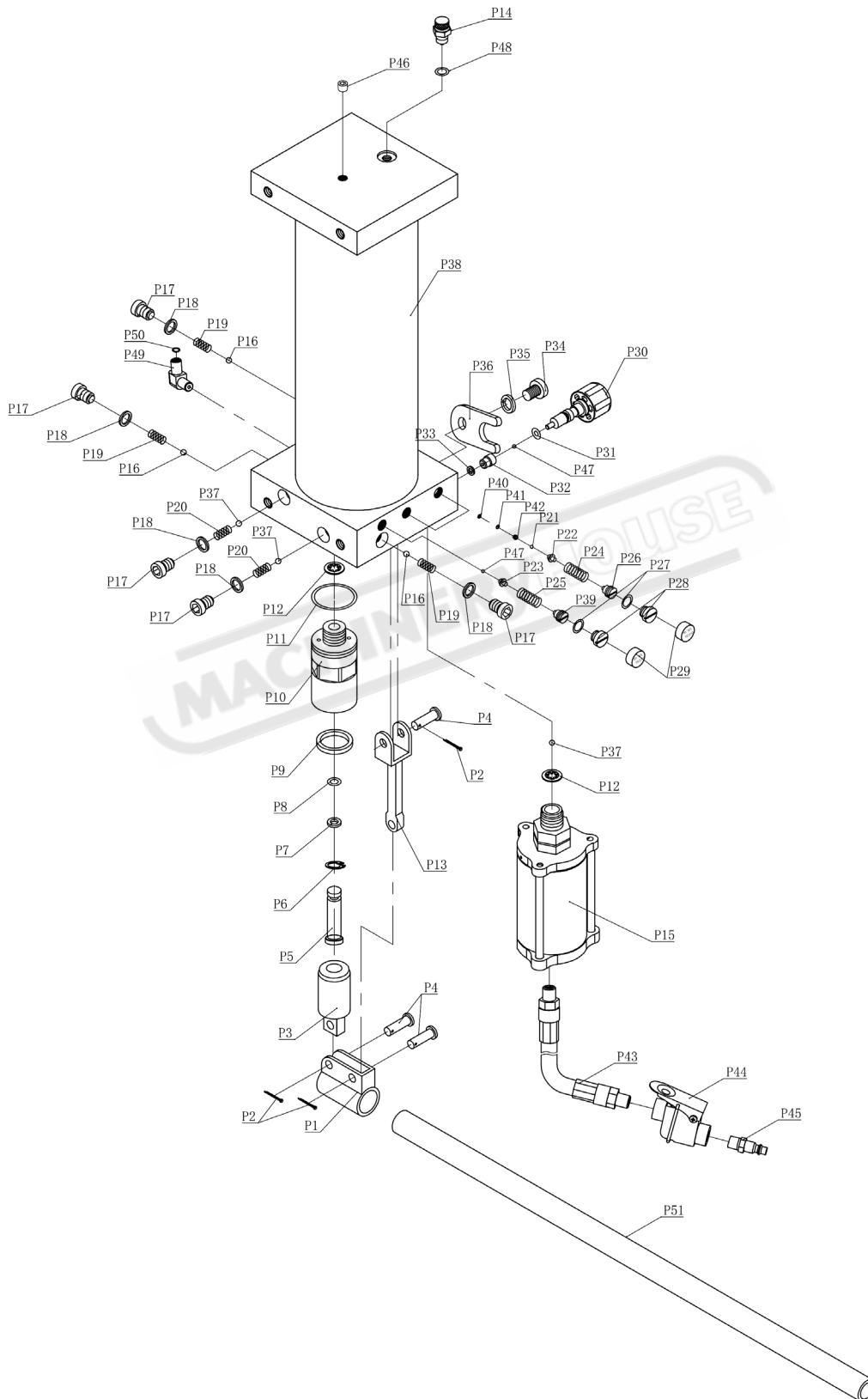

**HP-30P PUMP SPARE PARTS LIST**

No.	Description	Qty	No.	Description	Qty
P1	Socket	1	P27	O-ring	3
P2	Pin	2	P28	Screw	3
P3	Big pump core	1	P29	Cap	3
P4	Pin	3	P30	Release valve assy	1
P5	Small pump core assy	1	P31	O-ring	1
P6	Retaining ring	1	P32	Release valve seat	1
P7	PTFE washer	1	P33	Washer	1
P8	O-ring	1	P34	Screw	1
P9	U-ring	1	P35	Locking washer	1
P10	Pump core seat	1	P36	U limit	1
P11	O-ring	1	P37	Steel ball	3
P12	Copper washer	2	P38	Pump assy	1
P13	Connector bar	1	P39	Screw	1
P14	Screw assy	1	P40	Copper washer	2
P15	Air pump	1	P41	Washer	2
P16	Steel ball	3	P42	Screw	2
P17	Screw	5	P43	Air hose assy	1
P18	Washer	5	P44	Air valve assy	1
P19	Spring	3	P45	Connector	1
P20	Spring	2	P46	R pin	1
P21	Valve ball	2	P47	Steel ball	2
P22	Steel ball seat	2	P48	Nylon washer	1
P23	Steel ball seat	1	P49	Joint	1
P24	Spring	2	P50	O-ring	1
P25	Spring	1	P51	Handle	1
P26	Screw	2	P52	Oil hose	1

**HP-30P RAM SPARE PARTS DIAGRAM**

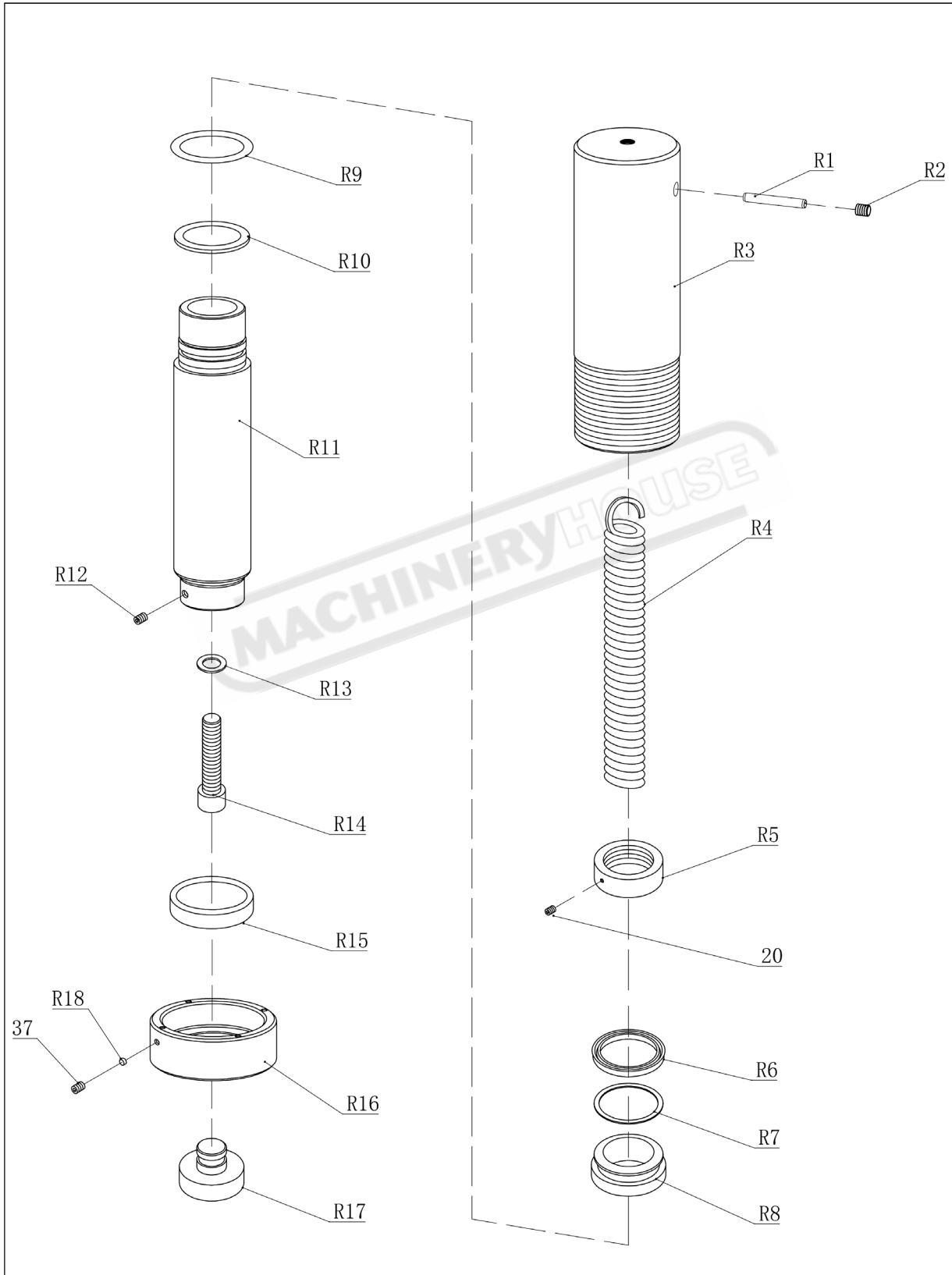

**HP-30P RAM SPARE PARTS LIST**

No.	Description	Qty	No.	Description	Qty
R1	Pin	1	R11	Piston rod	1
R2	Screw	1	R12	Screw	1
R3	Cylinder assy	1	R13	Copper washer	1
R4	Spring	1	R14	Screw	1
R5	Nut	1	R15	Limit ring	1
R6	U-ring	1	R16	Nut	1
R7	PTFE washer	1	R17	Saddle	1
R8	Piston saddle	1	R18	Nylon block	1
R9	O-ring	1	20	Screw	1
R10	PTFE washer	1	37	Screw	1

MACHINERYHOUSE

**HP-30P PRESS SPARE PARTS DIAGRAM**

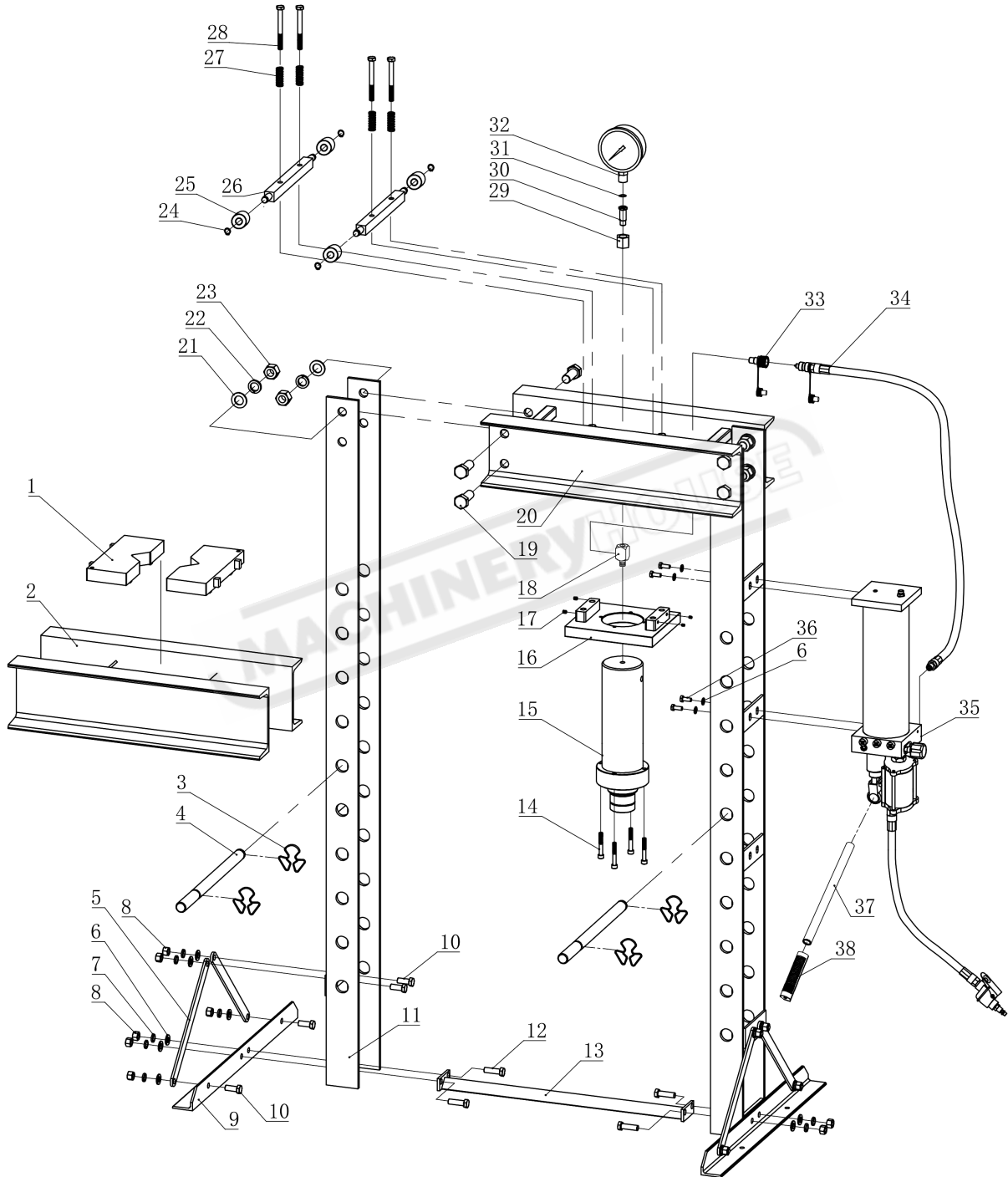

**HP-30P PRESS SPARE PARTS LIST**

No.	Description	Qty	No.	Description	Qty
1	Blocks	2	20	Upper beam	1
2	Down beam	1	21	Washer	8
3	Retaining ring	4	22	Locking washer	8
4	Pin	2	23	Nut	8
5	Support	4	24	Retain ring	4
6	Washer	16	25	Roller	4
7	Locking washer	12	26	Fixed beam	2
8	Nut	12	27	Spring	4
9	Base section	2	28	Bolt	4
10	Bolt	8	29	Nut	1
11	Post assy	2	30	Connector	1
12	Bolt	4	31	Nylon washer	1
13	Base section bar	1	32	Gauge	1
14	Screw	4	33	Connector assy	1
15	Ram assy	1	34	Oil hose assy	1
16	Mounting plate	1	35	Pump assy	1
17	Screw	4	36	Bolt	4
18	Connector	1	37	Handle	1
19	Bolt	8	38	Handle assy	1