

### **3.3. Operation Recommendations**

- Select the correct saw blade with the correct tooth pitch and form to suit the material to be cut to provide minimum burr and maximum blade lifespan.
- Use the smallest diameter blade and coarsest pitch that is practical within the required speed and material limitations.
- Generally use a tooth pitch to give 2 - 4 teeth engagement with the material during cutting.
- Ensure that sufficient coolant is flowing over the cutting teeth.
- Do not allow the machine's gearbox to run idle in the upright position for more than **3 minutes** otherwise, damage can occur to the drive system.
- The rate of feed affects the quality of the final cut and blade life. This varies also by the material and cross-sectional dimensions. When cutting stainless steel or high carbon steel (**Brinell hardness above 200**), the slowest speed machine should be used together with a cobalt type high speed steel blade.
- When manually feeding the saw head, keep in mind to maintain a steady, continuous pressure, thus **avoiding work hardening** on the cutting piece. Avoid 'forcing' the blade through the material as this might damage or break the blade.
- As a rule of thumb **the softer the component, the faster the rate of speed**. Thus, it is recommended that slower speeds be used for hard and tough materials and higher speeds for soft, ductile materials. Note that for non-ferrous materials such as brass, copper, aluminium etc. require much faster speeds than provided on this machine. If these are the majority of materials cut, a **Brobo NF Series** machine should be considered.

## **CHAPTER 4 - Drawings, Layouts, Assembly and Spare Parts**

---

**DO NOT SCALE**  
COMMERCIAL STOCK SIZES EXCEPTED AND UNLESS OTHERWISE NOTED  
TOLERANCES IN DIMENSIONS ARE:  
METRIC  
Size To Mach. Cost  
6 mm ± 0.1 ± 0.5  
30 mm ± 0.2 ± 1.0  
100 mm ± 0.3 ± 1.5  
300 mm ± 0.5 ± 2.0  
1000 mm ± 0.8 ± 3.0  
2000 mm ± 1.2 ± 5.0  
\* INCLUDES STRUCTURAL STEEL WORK.  
REMOVE ALL BURRS AND SHARP EDGES BY 0.3 x 45° UNLESS OTHERWISE STATED  
SURFACE FINISH

Roughness Value	
Met Units	Grade No.
50	N12
25	N11
12.5	N10
6.3	N9
3.2	N8
1.6	N7
0.8	N6
0.4	N5
0.2	N4
0.1	N3
0.05	N2
0.025	N1

DRAWING PRACTICE TO AS 1100 - PROJECTION SYSTEM (UNLESS NOTED)

3RD ANGLE

ANGULARITY TOLERANCE < 0° 7'

CONCENTRICITY 0.1 mm

THIS DESIGN OR DRAWING IS NOT SOLD, BUT LENT AND IS SUBJECT TO RECALL. REPRODUCTIONS OF THIS DRAWING IN ANY MATERIAL FORM ARE RESERVED TO BROBO WALDOWN Pty. Ltd. UNDER COPYRIGHT LAW.

NOTES:  
1/ PROVIDE END FLOAT OF 0.1 MM BY USING SHIMS IF REQUIRED.

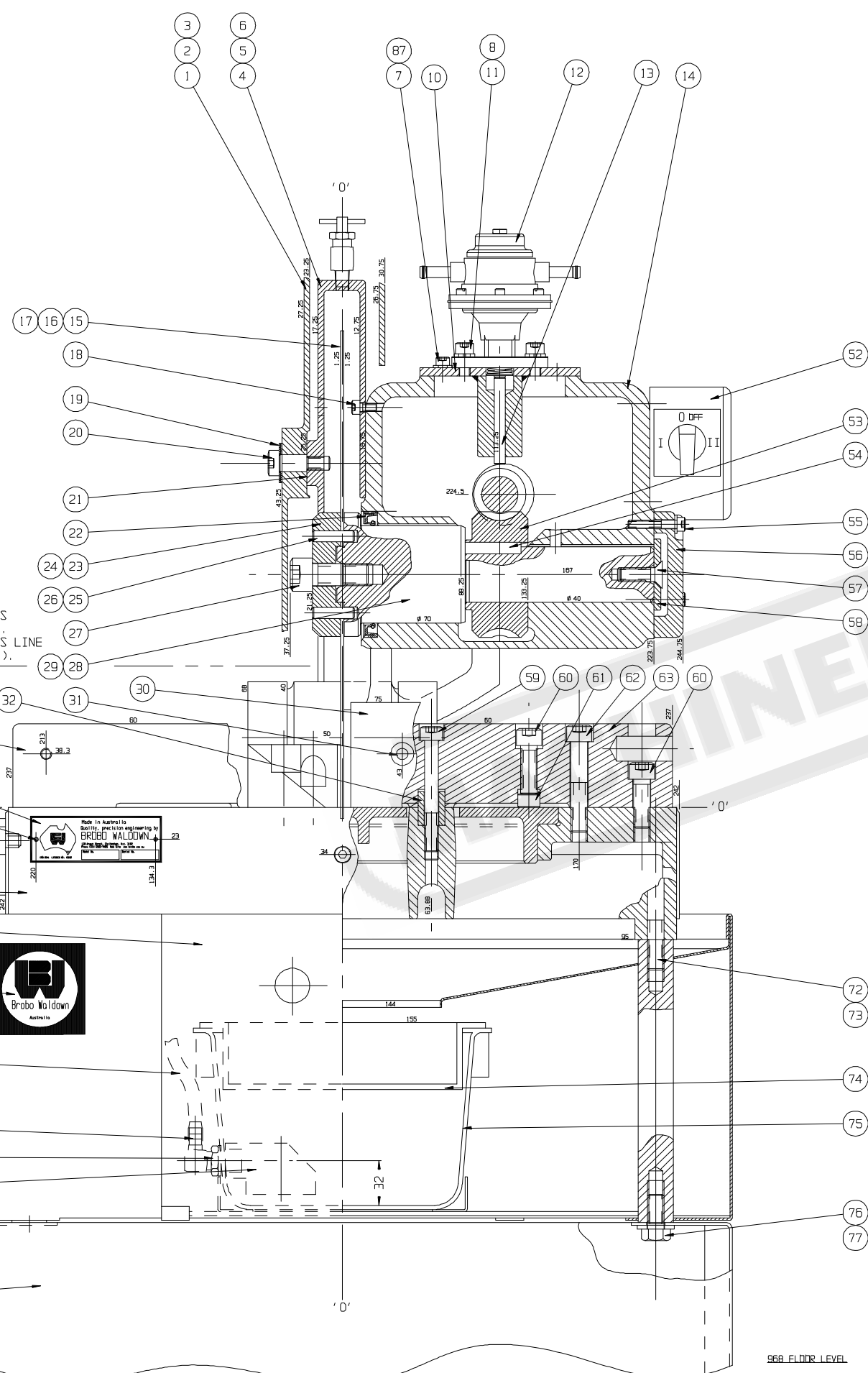

87	8705840	16	SPRING WASHER Ø 6		
86	8705070	4	SOCKET HEAD CAP SCREW M6 X 20		
85	9315040	1	DIL SEAL Ø 30 X Ø 52 X 7		TC12495
84	9504160	1	CLEAR PLASTIC HOSE Ø 8 I.D. X 300 LG		USE 9505030
83	9312100	1	RETAINER RING (CAST IRON)	A4	
82	9305030	1	TAPER ROLLER BRG. Ø 30 X Ø 72 X 20.75		TYPE 30306
81	9105050	1	TAP		
80	9502120	2	SPRING CLEVIS	A4	
79	9324000	1	WORM SHAFT	A4	
78	9305140	1	HEX LOCK NUT M20 X 1.5		
77	8705810	4	FLAT WASHER Ø 12		
76	8705650	4	HEX HEAD SCREW M12 X 25		
75	9505540	1	COOLANT TANK (PLASTIC)	A4	
74	9523040	1	CHIP BASKET (PERFORATED SHEET)	A4	
73	8705270	2	SOCKET HEAD CAP SCREW M12 X 60		
72	8705300	2	SOCKET HEAD CAP SCREW M12 X 100		
68	8705130	2	SOCKET HEAD CAP SCREW M8 X 25		
63	9332060	1	BACK FENCE RH (CAST IRON)	A3	
62	8705280	4	SOCKET HEAD CAP SCREW M12 X 65		
61	9304220	2	LOCKING PAD Ø 15 X 15 (BRASS)	A4	
60	8705250	4	SOCKET HEAD CAP SCREW M12 X 40		
59	8705210	2	SOCKET HEAD CAP SCREW M10 X 80		
58	9304130	1	RETAINER WASHER Ø 55 X 10	A4	
57	8705420	1	FLAT HEAD SOCKET SCREW M10 X 25		
56	9302110	1	COVER PLATE (CAST AL.)	A4	
55	8705090	3	SOCKET HEAD CAP SCREW M6 X 35		
54	9314420	1	KEY 12 X 8 X 40 LG	A4	
53	9314050	1	WORMWHEEL	A4	
52	9540000	1	ELECTRICAL ARRANGEMENT S300-S400	A3	SHEET 3 OF 3
51	9303040	1	MACHINE STAND WELDMENT - ONE PIECE	A3	
50	9505005	1	BRASS FILTER SCREEN - G0SS MS1223		
49	9503060	1	FILTERING DISK	A4	
48	1005230	1	CIRCLIP INTERNAL Ø 42		FROM FESTO
47	9302220	1	FILTER HEAD SOCKET HEAD (CAST AL.)	A3	
46	9305970	1	REDUCING BUSH D-1/4"-3/8"		
45	9505460	1	SINGLE BARBED ELBOW 5/16" X 1/4" BSPT		
44	9533000	1	MACHINE BASE WELDMENT/COOLANT TANK	A2	
43	9504170	1	CLEAR PLASTIC HOSE Ø 8 I.D. X 1500 LG		USE 9505030
42	8115090	1	TABLE - SMALL	A4	
41	9533010	1	FRONT PANNEL (SHEET METAL)	A4	
40	9312000	1	CLAMPING TABLE (CAST IRON)	A1	
39	9501250	1	CONVEYOR MOUNTING BRACKET - RH	A3	
38	9501240	1	CONVEYOR MOUNTING BRACKET - LH	A3	
35	8715730	2	DRIVE PIN NO. 2		
34	1065100	1	SERIAL NUMBER PLATE	A4	
33	9332070	1	BACK FENCE LH (CAST IRON)	A3	
32	9304770	2	HOLLOW DDWEL Ø 22 X 30	A4	
31	8705380	4	FLAT HEAD SOCKET SCREW M8 X 16		
30	9514280	2	WEAR PLATE LH & RH	A4	
29	9814010	1	MAIN SPINDLE - S400	A3	
28	9504080	1	MAIN SPINDLE - S315/S350	A3	
27	8735090	1	SOCKET HEAD CAP SCREW M16 X 40 LH	A4	
26	8735360	2	DDWEL PIN Ø 10 X 30		FOR S400
25	8715080	2	DDWEL PIN Ø 8 X 25		FOR S315/S350
24	9824000	1	COUNTER PLATE - S400	A4	
23	9504090	1	COUNTER PLATE - S315/S350	A4	
22	9305010	1	DIL SEAL Ø 70 X Ø 90 X 10		PR4277
21	1033010	2	SHIM Ø 25 X Ø 17 X 0.1	A4	
20	8705440	1	SOCKET HEAD SHOULDER SCREW Ø 12 X 20 X M10		
19	8715260	2	DISC SPRING Ø 28 X Ø 12.2 X 1.0		QTY. AS REQ.
18	8705050	5	SOCKET HEAD CAP SCREW M6 X 12		
17	9035140	1	SAWBLADE Ø 400 X 3 X Ø 40 X 200 TEETH		HSS 4.04 T.P.I.
16	9025800	1	SAWBLADE Ø 350 X 2.5 X Ø 40 X 180 TEETH		HSS 4.16 T.P.I.
15	9015880	1	SAWBLADE Ø 300 X 2.5 X Ø 40 X 160 TEETH		HSS 4.31 T.P.I.
14	9512000	1	SAW HEAD/GEARBOX - 315/350/400	A1	CAST IRON
13	9304017	1	PIN - COOLANT PUMP	A4	
12	9405450	1	COOLANT PUMP (G0SS G 6923/ORDINA 1895/6)		INC. GASKET
11	8705120	2	SOCKET HEAD CAP SCREW M8 X 20		
10	9324070	1	COVER PLATE (PUMP TO GEARBOX)	A3	
9	8705350	8	FLAT HEAD SOCKET SCREW M6 X 16		
8	8705850	6	SPRING WASHER Ø 8		
7	8705060	12	SOCKET HEAD CAP SCREW M6 X 16		
6	9802000	1	INNER GUARD - 400 (CAST AL.)	A3	
5	9502040	1	INNER GUARD - 350 (CAST AL.)	A3	
4	9302030	1	INNER GUARD - 315 (CAST AL.)	A3	
3	9505210	1	TABLE (WARNING STICKER)	A4	
2	9532050	1	OUTER GUARD - 350/400 (CAST AL.)	A3	
1	9342040	1	OUTER GUARD - 315 (CAST AL.)	A3	
107	9304170	1	QUICK ACTION NUT	A4	
106	9314090	1	VICE LOCKING HANDLE	A4	
105	9305350	1	SHIM Ø 50 X Ø 62 X 0.1		QTY. AS REQ.
104	9405020	1	WINDOW GASKET Ø 1/2" BSP		
103	9405010	1	DIL SIGHT WINDOW 1/2" BSP		
102	1045020	1	KNOB Ø 38 X M12 - BLACK		
101	9305020	1	TAPER ROLLER BRG. Ø 30 X Ø 62 X 17.25		TYPE 30206
100	9302120	1	BEARING COVER PLATE (CAST AL.)	A4	
99	9605260	1	CUP PLUG (PLASTIC)		
98	9505250	1	HANDLE GRIP		
97	9504110	1	OPERATING HANDLE	A4	
96	9554030	1	SPRING BRACKET UPPER	A4	
95	9305150	1	COMPRESSION SPRING	A4	
94	8735160	2	NYLOC NUT M8		
93	9314690	1	SHOULDER SCREW BR. M.S. Ø 16 X 60	A4	
92	9304660	1	SPACER Ø 39 X Ø 28 X 13	A4	BALDDR
91	9504120	1	SPACER Ø 39 X Ø 24 X 14	A4	CMG MOTOR
90	9301430	1	COUPLING SET Ø 25 X Ø 28		BALDDR MOTOR
89	9301420	1	COUPLING SET Ø 25 X Ø 24		CMG MOTOR
88	9304430	1	KEY 8 X 7 X 31	A4	

Rev	Part No.	Qty.	Name & Material	Sheet	Remark
E	REVISED				
D	SPRING AND UPPER SPRING BRACKET REVISED				
C	P/N S 9324070, 9405450 WERE 9314070, 9505230, P/N 9304017 ADDED				
B	P/N 9312030 WAS 9302030 & COOLANT MANIFOLD REPLACED WITH NOZZLE				
A	REDRAWN ON COMPUTER				

**BROBO WALDOWN**  
 AUSTRALIA Pty Ltd  
 Drg No. **9540000**  
 SHEET 1 OF 3  
 Revision



DO NOT SCALE

COMMERCIAL STOCK SIZES EXCEPTED AND UNLESS OTHERWISE NOTED TOLERANCES ON DIMENSIONS ARE:

METRIC

Size To	Mach.	Cast*
6 mm	± 0.1	± 0.5
30 mm	± 0.2	± 1.0
100 mm	± 0.3	± 1.5
300 mm	± 0.5	± 2.0
1000 mm	± 0.6	± 3.0
2000 mm	± 1.2	± 5.0

\* INCLUDES STRUCTURAL STEEL WORK.

REMOVE ALL BURRS AND SHARP EDGES BY 0.3 x 45° UNLESS OTHERWISE STATED

SURFACE FINISH

Roughness Value

	Roughness Value	
	Met Umm	Grade No.
ROUGH	50	N12
	25	N11
	12.5	N10
MED	6.3	N 9
	3.2	N 8
FINE	1.6	N 7
	0.8	N 6
S. FINE	0.4	N 5
	0.2	N 4
POLISH	0.1	N 3
	0.05	N 2
	0.025	N 1

DRAWING PRACTICE TO AS 1100 - PROJECTION SYSTEM (UNLESS NOTED)

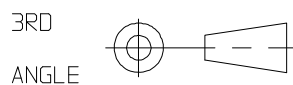

ANGULARITY TOLERANCE < 0' 7"



THIS DESIGN OR DRAWING IS NOT SOLD, BUT LENT AND IS SUBJECT TO RECALL. REPRODUCTIONS OF THIS DRAWING IN ANY MATERIAL FORM ARE RESERVED TO BROBD WALDOWN Pty. Ltd. UNDER COPYRIGHT LAW.

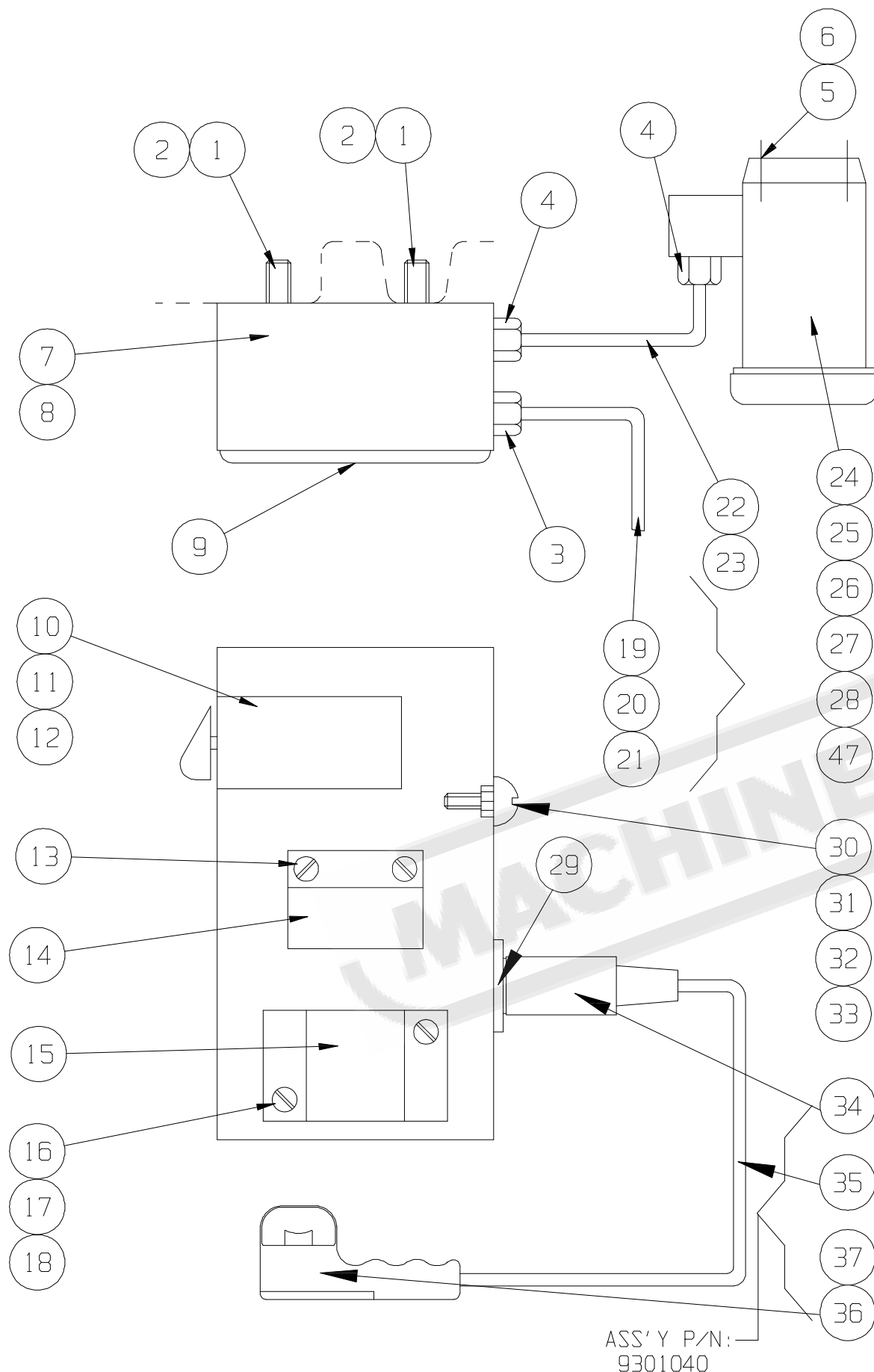

ASS'Y P/N: 9301040

45	9904100	1	LEAD - TRANSFORMER FEED	A4	
44	9504210	2	JUMPER LEAD	A4	
43	8745180	12	CABLE TIE 412mm LG.		
42	8725210	4	EYELET		
41	8725290	15	SPADE		
40	9504250	1	JUMPER LEAD	A4	
39	9504240	4	JUMPER LEAD	A4	NOT SHOWN
38	9504220	3	JUMPER LEAD	A4	NOT SHOWN
37	9104010	1	OPERATING HANDLE BAR MS PIPE	A4	
36	9105040	1	OPERATING HANDLE SWITCH WITH ENCLOSURE		
35	9304400	1	OPERATING SWITCH LEAD	A4	MAT: 8745100
34	9615500	1	SOCKET		
33	8725650	2	LOCK WASHER		
32	8705770	2	FLAT WASHER Ø 5		
31	8705700	2	HEX. NUT M5		
30	8715310	1	ROUND HD. SLOTTED SCREW M5 x 20 LG. (EARTH)		
29	9615490	1	PLUG		
28	9505620	1	MOTOR 440V, 3PH, 8/4POLE, 1.1/1.5kW, 60Hz		L90 FRAME, FACE MOUNT
27	9505080	1	MOTOR 415V, 3PH, 8/4POLE, 1.1/1.5kW, 50Hz		L90 FRAME, FACE MOUNT
26	9505010	1	MOTOR 415V, 3PH, 4/2POLE, 1.5/2.2kW, 50Hz		L90 FRAME, FACE MOUNT
25	9505150	1	MOTOR 220V, 3PH, 8/4POLE, 1.1/1.5kW, 60Hz		L90 FRAME, FACE MOUNT
24	9505220	1	MOTOR 240V, 1PH, 4POLE, 1.7kW, 50Hz		L90 FRAME, FACE MOUNT
23	9304850	1	MOTOR LEAD 3PH, (ASS'Y) 2 SPED	A4	
22	9304860	1	MOTOR LEAD 1PH, (ASSEMBLY)	A4	
21	9304870	1	SUPPLY LEAD 3PH, (ASSEMBLY)	A4	
20	9314540	1	SUPPLY LEAD 1PH, (NO PLUG FOR USA)	A4	
19	9501280	1	SUPPLY LEAD 1PH, 15AMP	A4	
18	8705760	2	FLAT WASHER Ø 4		
17	8705690	2	HEX. NUT M4		
16	8715280	2	ROUND HD. SLOTTED SCREW M4 x 12 LG.		
15	9315190	1	TRANSFORMER 220-440/24V, 50/60Hz		
14	9315220	1	CONTACTOR		
13	8715850	2	ROUND HD. SLOTTED SCREW M3 x 10 LG.		
12	9305960	1	SWITCH, ROTARY CAM		(N.S.W.-P.W.D.)
11	3835190	1	SWITCH, ROTARY CAM, 1PH & 3PH, 1 SPEED		
10	9305180	1	SWITCH, ROTARY CAM, 3PH, 2 SPEED		
9	9505200	1	LABEL, ELECTRICAL WARNING	A4	
8	9364810	1	ENCLOSURE, LARGE (WITH DEADMAN SWITCH)	A3	USE : 9305880
7	9524130	1	ENCLOSURE, SMALL (STD MACHINE)	A3	USE : 9505260
6	8705850	4	SPRING WASHER Ø 8		
5	8705130	4	SOC. HD. CAP SCREW M8 x 25 LG.		
4	3215270	2	CORDCLAMP STB13		ONLY IF 2 SPEED MOTOR FITTED
3	9305600	1	CORDCLAMP R20		
2	8705780	2	FLAT WASHER Ø 6		
1	8705050	2	SOC. HD. CAP SCREW M6 x 12 LG.		

Det.	Part No.	Qty.	Name & Material	Sheet	Remark
RAW MAT. #.	Drawn	ANH	Scale	N.T.S.	
Mass in Kg.	Date	02/06/2017	Checked		
Mat/Spec	Titled	ELECTRICAL ASSEMBLY DIAGRAM S315D, S350D, S400B		Drg No.	9540000
AS LISTED				SHEET 3 OF 3	Revision

